

ExoTec®
FACADE PANEL

Top Hat Rainscreen Technical Specification

August 2010 / New Zealand

 **James Hardie**
a smarter way™

Contents

1	Application and scope	3			
1.1	Application	3	7.3	Base	9
1.2	Scope	3	7.4	Soffit Junction	9
1.3	Details	3	7.5	Abutments	9
1.4	Specific Design and Detailing	2	8	Corners	9
2	Design	3	9	Windows	9
2.1	Compliance	3	10	Special details	9
2.2	Responsibility	3	10.1	Curved Facades	9
2.3	Site and Foundation	4	10.2	Parapet Capping	9
2.4	Clearances	4	10.3	Inspection	10
2.5	Moisture Management	4	11	Finishes	10
2.6	Framing and Top Hat Sections	4	11.1	General	10
2.7	Wind Pressure	4	11.2	Panels Exposed to Direct Sunlight	10
2.8	Fastener Spacing	6	12	Storage and handling	10
2.9	Fire Rated Walls	6	13	Maintenance	10
3	Substructure and preparation	6	14	Product information	11
3.1	Substructure	6	14.1	Manufacturing and Classification	11
3.2	RAB Board	6	14.2	Product Mass	11
3.3	Building Wrap	6	14.3	ExoTec Facade Panel	11
3.4	Flashing	6	14.4	RAB Board	11
4	ExoTec Top Hat and panel layout	7	14.5	Durability	11
4.1	General	7	14.6	Resistance to Moisture/Rotting	11
4.2	Panel Orientation and Layout	7	14.7	Resistance to Fire	11
5	Fixing	7	14.8	Alpine Regions	11
5.1	General	7	15	Safe working practice	12
5.2	Fastener Durability	7	16	Product and accessories	14
5.3	Countersunk Fasteners	7	17	Details	17
5.4	Exposed Head Fasteners	7	18	Product warranty	35
5.5	ExoTec Top Hat Fixing	8			
6	Joints	8			
6.1	Panel Joints	8			
6.2	Vertical Panel Joints	8			
6.3	Horizontal Panel Joints	8			
6.4	Jointing in Very High Wind Pressure	8			
6.5	Flashing Overlaps	8			
6.6	Movement Joints	8			
6.6.1	Vertical Structural Joints	8			
6.6.2	Horizontal Structural Joints	8			
7	Junctions	9			
7.1	Slab Junctions	9			
7.2	Head	9			

WE VALUE YOUR FEEDBACK

To continue with the development of our products and systems, we value your input. Please send any suggestions, including your name, contact details, and relevant sketches to:

Ask James Hardie™

Fax 0800 808 988

literaturefeedback@jameshardie.co.nz

1 Application and scope

1.1 APPLICATION

James Hardie ExoTec® Facade Panel fixed as per this technical specification provides a durable, expressed joint panel appearance for building facades and fascias. This fixing method offers versatility to architects and builders which is demonstrated by the variety of design styles that can be achieved including curved walls, vertical / horizontal panel layout or brick pattern layout. A wide range of decorative finishes can be used, from site-applied acrylic textures, to factory-applied polyurethane plain colours can also be used. Metallic finishes provided by some specialist applicators.

If you are a specifier

Or other responsible party for a project, ensure that the information in this document is appropriate for the application you are planning and that you undertake specific design and detailing for areas which fall outside the scope of these specifications.

If you are an installer

Ensure that you follow the design, moisture management and associated details and material selection provided by the designer. All the details provided in this document must be read in conjunction with this specification manual and the project specification.

Make sure your information is up to date

When specifying or installing James Hardie products, ensure you have the current manual. If you are not sure you do, or you need more information, visit www.jameshardie.co.nz or Ask James Hardie on 0800 808 868.

1.2 SCOPE

This technical specification covers the installation of ExoTec Facade Panel on ExoTec Top Hats up to a wind pressure of 5kPa(ULS). This specification is intended for use by architects, designers / specifiers and installers who may be involved with the specification of ExoTec Facade Panel, ExoTec Top Hats and their installation.

This specification covers the use of ExoTec Facade Panel and ExoTec Top Hats for commercial facade application over timber or steel frame, masonry and concrete walls. The ExoTec Facade Panel and ExoTec Top Hats can also be used to provide an expressed joint panel appearance in building soffits.

All the information and details within James Hardie ExoTec Top Hat Rainscreen technical specification only applies to the installation ExoTec Facade Panel. These panels may be used in curved facade applications depending on the curve radius, refer to Clause 10.1 for more information.

1.3 DETAILS

Various ExoTec Facade Panel details are provided in the Details section of this document. These details are available in CAD format and are available to download from our website at www.jameshardie.co.nz.

All dimensions shown are in millimeters unless noted otherwise. All New Zealand standards referenced in this manual are current edition and must be complied with.

1.4 SPECIFIC DESIGN AND DETAILING

For the use of ExoTec Facade Panel and ExoTec Top Hats outside the scope of this technical specification, the designer, architect or engineer must undertake the required specific engineering design.

Any project specific detail not included in this literature, must be developed by the designer and included on the project drawings.

For a guidance on specific engineering designs, Ask James Hardie on 0800 808 868.2 DESIGN

2 Design

2.1 COMPLIANCE

ExoTec Facade Panel installed over ExoTec Top Hats as per this technical specification has been tested in a NATA (National Association of Testing Authorities) accredited laboratory and complies with B1, B2 and E2 requirements of the New Zealand Building Code (NZBC). All designs outside the scope of this specification must satisfy the relevant clauses of the NZBC and other relevant standards and current regulations.

2.2 RESPONSIBILITY

The specifier/designer or any party responsible for the project is responsible for ensuring that the information and details included in this specification are suitable for the intended application.

The specifier shall accommodate the appropriate provisions required by the NZBC. Careful detailing of all penetrations through the air barrier and rainscreen is required and they must be appropriately flashed and weatherproofed. The other materials and components that are used to manage moisture must be installed as per their manufacturer's instructions and comply with the requirements of relevant Standards and the NZBC.

The designer/specifier must ensure that all the reference documents and standards referred to during the design and construction process are current. The designer must identify the moisture related risks associated with the particular building design. The design and construction must effectively manage the external moisture.

The windows to be used with ExoTec Facade Panel must be specifically designed considering the design wind pressures and deflection in building facade/structure. Refer to the window manufacturer/suppliers for information regarding their specifications and installation requirements. For the latest information in relation to designing for weathertightness, refer to www.branz.co.nz and www.dbh.govt.nz websites.

James Hardie conducts regular quality checks to ensure that the manufactured products falls within our quality spectrum. It is the responsibility of the builder/installer to ensure that the product meets their aesthetic requirements before installation. James Hardie will not be responsible for rectifying obvious aesthetic surface variations following the installation.

2.3 SITE AND FOUNDATION

The site on which the building is situated must comply with E1- 'Surface Water' clause of NZBC. The grade of adjacent finished ground must slope away from the building to avoid any possibility of water accumulation in accordance with NZBC requirements. The foundation slab or footings of the structure must be based on 'Good Ground' as defined in the approved document of NZBC B1 'Structure'. The foundation must be designed by a qualified structural engineer in accordance to relevant codes, regulations and standards.

2.4 CLEARANCES

ExoTec Facade Panel must always have a minimum clearance of 100mm from paved ground and 175mm from unpaved ground. On the roofs and decks a 50mm minimum clearance must be provided and this must always be maintained. ExoTec Facade Panel must overhang by 50mm minimum below the bottom plates.

Do not install external cladding such that it may remain in contact with standing water.

2.5 MOISTURE MANAGEMENT

The ExoTec Facade Panel installed over ExoTec Top Hats acts as a rainscreen. To achieve a particular level of weathertightness, the designer must determine the appropriate moisture managing details for the project. The designer should consider the following matters when making this decision:

- It is the responsibility of the builders and designers to identify moisture related risks associated with any particular building design. It is the responsibility of a builder to ensure that appropriate level of moisture management is achieved by proper use of flashings, sealants and vapour permeable membranes etc. Before installing panels, all wall openings, penetrations, intersections, connections, window sills, heads and jambs must incorporate appropriate flashings for moisture management. Materials, components and the installation practices required to manage moisture must, at a minimum, comply with the requirements of NZBC, relevant standards and the manufacturer's specifications.
- Exposed joints in ExoTec Facade Panel must be provided as detailed in this literature, see Clauses 6.2 and 6.3. For wind pressures above 4.0kPa, both vertical and horizontal joints must be filled with a suitable paintable flexible sealant. Refer to Clause 6.4 for suitable joint sealant. Refer to the sealant manufacturer for sealant durability information.
- For walls higher than 10m, a horizontal drainage joint must be provided. Refer to Figure 24.
- The installation of vermin proofing/base mould at the base of a cavity must not restrict ventilation or drainage of the cavity. Refer to Figure 4.

For information on RAB™ Board and building wraps refer to Clause 3.2 and 3.3 of this technical specification.

2.6 FRAMING AND TOP HAT SECTIONS

ExoTec Top Hats are fixed vertically over timber, steel girt or masonry substrates. The framing to support the ExoTec Top Hat sections must be provided in accordance with specific engineering design requirements of the project and must be suitable to fix ExoTec Top Hat sections over it. The specific engineering design must be in accordance with AS/NZS 1170. The flatness of framing must comply with the expected aesthetic requirement set for the project. Straightening or packing out between the substructure and ExoTec Top Hats must be limited to 20mm maximum and must be done behind the ExoTec Top Hat sections. ExoTec Facade Panels must only be fixed to ExoTec Top Hats and ExoTec Intermediate Top Hats and ExoTec accessories as shown in details. Refer to Figure 3. ExoTec Top Hat and Intermediate Top Hat sections must not be installed horizontally.

ExoTec Top Hats are required at panel edges and ExoTec Intermediate Top Hats in the middle of panels. The ExoTec Top Hats fixed at panel edges have the flat surface sitting on the framing and the ExoTec Intermediate Top Hat has the flat surface facing towards the rear face of panels. Refer to Figure 5.

The maximum spans and nominal spacing for fixing ExoTec Top Hats and ExoTec Intermediate Top Hats for wall and soffit applications are provided in Table 1 and 2 respectively. For wall applications, the maximum cantilever distance the ExoTec Top Hat can span up to is 1/4 of the single span given in Table 1.

2.7 WIND PRESSURE

It is a responsibility of the project engineer to determine the appropriate wind pressures for the project and select suitable fixing of the ExoTec Top Hats and ExoTec Intermediate Top Hats to the structure. The calculated wind pressure for a facade must include the localised coefficients as defined in AS/NZS 1170. The engineer must limit the deflection of the supporting structure to span/250 for serviceability wind load.

ExoTec Facade Panel installed over ExoTec Top Hats has been tested to withstand wind pressures up to 5kPa (ULS).

Table 1 and 2 specify the spans for ExoTec Facade Panels and ExoTec Top Hat Sections depending upon the design wind pressures.

Table 4 specifies the fixing spacing for installing ExoTec Facade Panel to ExoTec Top Hat sections.

Table 3 specifies the design capacity required for the fasteners that should be used to fix ExoTec Top Hat sections to the framing substrates.

Table 1

Walls — maximum ExoTec Top Hat and ExoTec Intermediate Top Hat spans (mm) for ultimate design wind pressures										
SPAN TYPE	NOMINAL TOP HAT SPACING	DESIGN WIND PRESSURE (KPA)								
		(mm)	1.0	1.5	2.0	2.5	3.0	3.5	4.0	4.5
Single Span	400	1750	1530	1390	1290	1210	1150	1100	1060	1020
	600	1530	1330	1210	1120	1060	1010	960	930	890
2 Span Continuous	400	2340	2050	1860	1720	1620	1470	1350	1260	1160
	600	2050	1790	1620	1400	1250	1140	1030	960	880
3 Span Continuous	400	2160	1890	1710	1590	1500	1420	1350	1260	1160
	600	1890	1650	1500	1390	1250	1140	1030	960	880

Table 2

Soffits — maximum ExoTec Top Hat and ExoTec Intermediate Top Hat spans (mm) for ultimate design wind pressures										
SPAN TYPE	NOMINAL TOP HAT SPACING	DESIGN WIND PRESSURE (KPA)								
		(mm)	1.0	1.5	2.0	2.5	3.0	3.5	4.0	5.0
Single Span	400	1660	1470	1350	1260	1190	1130	1080	1010	
	600	1450	1290	1180	1100	1040	990	950	880	
2 Span Continuous	400	2220	1970	1810	1690	1550	1410	1300	1130	
	600	1950	1730	1530	1100	1200	1090	1000	860	
3 Span Continuous	400	2050	1820	1670	1560	1470	1400	1300	1130	
	600	1800	1590	1460	1340	1200	1090	1000	860	

Table 3

Fastener selection to fix ExoTec Top Hat section into framing											
SPAN TYPE	NOMINAL TOP HAT SPACING	DESIGN WIND PRESSURE (KPA)									
		(mm)	1.0	1.5	2.0	2.5	3.0	3.5	4.0	4.5	5.0
Single Span	400	Type 1	Type 1	Type 1	Type 1	Type 1	Type 1	Type 1	Type 1	Type 2	Type 2
	600	Type 1	Type 1	Type 1	Type 2	Type 2	Type 2	Type 2	Type 2	Type 2	Type 2
2 Span Continuous	400	Type 2	Type 2	Type 3	Type 3	Type 3	Type 3	Type 3	Type 3	Type 4	Type 4
	600	Type 2	Type 3	Type 3	Type 4	Type 4	Type 4	Type 4	Type 4	Type 4	Type 4
3 Span Continuous	400	Type 2	Type 2	Type 2	Type 2	Type 3	Type 3	Type 3	Type 3	Type 3	Type 3
	600	Type 2	Type 2	Type 3	Type 3	Type 4	Type 4	Type 4	Type 4	Type 4	Type 4

Note:

- Type 1 fastener to have a design capacity up to 1kN. Type 2 fastener to have a design capacity up to 2kN. Type 3 fastener to have a design capacity up to 3kN. Type 4 fastener to have a design capacity up to 4.2kN.
- Fastener spacing to fix Top Hat section is as per Table 1 and 2.

Table 4

Fastener spacings for wall and soffit applications			
DESIGN WIND PRESSURE (ULTIMATE) (KPA)	NOMINAL TOP HAT SPACING (MM)	MAX FASTENERS SPACING AT SHEET EDGES (MM)	MAX FASTENERS SPACING AT INTERMEDIATE TOP HATS (MM)
1.0 - 1.5	600	600	600
	400	600	600
1.5 - 2.5	600	400	400
	400	600	600
2.5 - 3.0	400	450	450
3.0 - 3.5	400	400	400
3.5 - 5.0	400	300	300

Notes to Tables 1, 2, 3 and 4:

1. ExoTec Top Hat spans may be restricted to framing spans required to fix RAB Board, when fixing ExoTec Top Hat sections into the same framing as used to fix RAB Board.
2. ExoTec Top Hat deflection for serviceability limit state design to AS/NZS 1170.2 is limited to span/250.
3. Design Wind Pressures to be in accordance with AS/NZS 1170.2 for ultimate strength design.
4. For permissible design wind pressure, divide the ultimate strength design wind pressures by 1.5.

2.8 FASTENER SPACING

Table 4 indicates the maximum fastener spacing to fix ExoTec Facade Panels into ExoTec Top Hat sections for wall and soffit applications.

2.9 FIRE RATED WALLS

Fire rated wall can be constructed when using rigid air barriers. A fire rating can be achieved when using RAB Board as rigid air barrier up to 60 minutes. The other fire rated system requirements must be included in the wall construction to achieve the required fire ratings. For more information, refer to James Hardie Fire and Acoustic Design Manual available at www.jameshardie.co.nz or Ask James Hardie on 0800 808 868 for a copy.

3 Substructure and preparation

3.1 SUBSTRUCTURE

The ExoTec Top Hat and ExoTec Intermediate Top Hat sections are installed vertically over steel girts or noggs. When using timber framing, the noggings between studs can be used to support ExoTec Top Hat and ExoTec Intermediate Top Hat sections. The

framing to which the ExoTec Top Hat sections are fixed must be structurally adequate to resist the facade loading. The timber framing used must be treated and have the moisture content within the 20% limit as specified in NZS 3602.

A qualified person must design the substructure to suit the design wind pressures and loading transferred from the facade to the substructure.

3.2 RAB BOARD

RAB Board is installed over the main framing to act as a rigid air barrier to withstand high wind pressures and to manage moisture in the cavity. RAB Board installed as a rigid air barrier has been tested to withstand wind pressures specified in Table 1.

RAB Board must be used with ExoTec Facade Panel Top Hat Rainscreen where the projects are exposed to wind pressures higher than 1.5kPa(ULS). The RAB Board must be fixed using 40 x 2.8mm HardieFlex™ nails at 300mm c/c to the entire timber framing.

Refer to the RAB Board Installation Manual or Ask James Hardie on 0800 808 868 for further information about fixing RAB Board.

Note: The framing requirement for fixing the RAB Board may restrict the ExoTec Top Hat span given in Table 1 when fixing ExoTec Top Hat sections into the same framing.

3.3 BUILDING WRAP

Building wrap is suitable to withstand a limited wind pressure and is generally used up to a wind pressure of 1.5kPa (ULS). A building wrap may not perform as desired when exposed to higher wind pressures for prolonged durations. Therefore when dealing with projects exposed to wind pressures higher than 1.5kPa, a RAB Board must be used.

When considering the use of a building wrap for a specific design project, check with the building wrap manufacturer to confirm its suitability for the proposed project. The building wrap is installed between the ExoTec Top Hats and the supporting structure. Refer to Figure 5. Building wrap must be lapped when required so as to drain moisture towards the exterior of a building.

The building wrap must be installed in accordance with the AS/NZS 4200.2 'Pliable Building Membranes and Underlays – Installation' and the manufacturer's specifications.

Building wrap must comply with Table 23 of Clause E2 of NZBC.

3.4 FLASHING

All wall openings, penetrations, intersections, connections, window sills, heads and jambs must be flashed prior to ExoTec Top Hat and ExoTec Facade Panel installation. Refer to Clause 2.5 for moisture management requirements.

The building wrap or RAB Board must be appropriately taped around the penetrations and lapped/taped to flashings. Materials must be lapped in such a way that water tracks down to the exterior of the building. James Hardie will assume no responsibility

5 Fixing

for water infiltration within the wall due to poor installation of flashings or building wraps. The selected flashing material must comply with the durability requirements of NZBC. For information refer to Table 20 of E2 of NZBC.

When using RAB Board the entire timber framing around the opening must be sealed with a flashing tape. The tape must be lapped over the face of RAB Board. The flashing tapes like Protecto tape by Protecto Wrap® or Aluband by Thermakraft® are recommended for use with RAB Board. Refer to tape manufacturer's literature for further information regarding their installation.

4 ExoTec Top Hat and panel layout

4.1 GENERAL

The ExoTec Facade Panel layout must be considered in conjunction with the ExoTec Top Hat spacing and substructure framing set out. ExoTec Top Hat spacing must be suitable for jointing the panels and the design wind pressures. Refer to Figure 3. Where construction joints occur in the structure, these must be carried through ExoTec Top Hats and panels. Refer to Figure 25.

4.2 PANEL ORIENTATION AND LAYOUT

ExoTec Facade Panel must be installed with distinctive white side facing the exterior of structure whereas the clear sealed side is facing towards the cavity. Refer to Clause 11.2 for specific requirements.

Panels are generally installed with a 10mm nominal expressed vertical joint between adjacent panels, i.e. for 1190mm wide panels and a 10mm wide joint, the grid dimension is 1200mm c/c. Refer to Figure 3. Vertical joints up to 20mm wide can be formed with additional care required during installation to ensure the panel edges cover the rubber fixed on both sides of ExoTec Gasket Snap Strip. A vertical joint up to 6mm minimum width can also be formed with care.

The horizontal and vertical expressed joints between different panels may either be aligned or offset to form a brick layout pattern.

Notes:

- Where feasible use stock panel sizes to minimise site cutting and wastage. See Section 16 for panel sizes.
- All site cut panel edges must be sealed with Dulux® Acraprime 501/1 or a similar sealer.

5.1 GENERAL

ExoTec Facade Panel is fixed to ExoTec Top Hat sections using the following fixings;

1. Countersunk screws fixed 2mm below the panel surface and flush finished using two part epoxy filler and sanded smooth. The panels are finished using a site-applied acrylic coating. Refer to Clause 5.3.
2. Exposed head screws, e.g. pan, wafer head hex screw along with ExoTec Facade washer. Exposed head fasteners can also be colour coated to match the pre-painted panels. Refer to Clause 5.4

5.2 FASTENER DURABILITY

Fasteners must have the appropriate level of durability required for the intended project. This is of particular importance in coastal areas, subject to salt spray and other corrosive environments.

Fasteners must be fully compatible with all other materials that they are to be in contact with to ensure the durability and integrity of the assembly.

In non-coastal areas a Class 3 coated screw and in coastal area a Class 4 coated screw must be used. Contact fastener manufacturers for more information.

See Table 4 and Figure 3 for maximum fastener spacing required for fixing panels to ExoTec Top Hats.

5.3 COUNTERSUNK FASTENERS

Fastener Type: 10g x 30mm countersunk head metal screw with required Class 3 or Class 4 coating. The countersunk screw holes are flush finished with a two part epoxy filler which is sanded to a smooth finish.

Note: Panels must be pre-drilled using a 9mm Tungsten Carbide Drill Bit supplied by James Hardie. Screw head must be countersunk to a maximum depth of 2mm below the panel surface. Refer to Figure 6.

Flush Sealing Screw Holes:

- Use only proven two part epoxies for sealing holes after fixing the screws. Hilti CA273, Nuplex Fairing Cream or a similar epoxy should be used.
- Mix correct ratio and amount of epoxy for immediate use as per the manufacturer's instructions.
- Blow dust out of holes to achieve adhesion of epoxy.
- Cover the counter sunk fasteners with two part epoxy, finish it flush with the panel surface and sand it to a required level of finish.

5.4 EXPOSED HEAD FASTENERS

Fastener Types: 10g x 25mm pan, wafer or hex head metal screw with required Class 3 or Class 4 coating. Refer to Figure 9.

ExoTec Facade Washers must be inserted in the pre drill screw holes before fixing the screws.

Note: Panels must be pre-drilled with a 6mm masonry titanium drill bit, which provides a 6.2 to 6.3mm diameter hole before fixing.

5.5 EXOTEC TOP HAT FIXING

For fixing the ExoTec Top Hat section into the framing substrate, the designer must specify the type of fastener to be used to withstand the design wind pressures. Refer to Table 3 for a guidance to check the design capacity of the fastener required.

The maximum fixing c/c distance will be as per the ExoTec Top Hat spans provided in Table 1 and 2 as the sections can only be fixed at support points.

6 Joints

6.1 PANEL JOINTS

ExoTec Facade Panels are generally installed with a nominal 10mm wide expressed joint between adjacent panels, vertically and horizontally.

6.2 VERTICAL PANEL JOINTS

At vertical panel joints, prior to fixing panels, the ExoTec Gasket Snap Strip is fitted into ExoTec Top Hats by starting on one side of the top hat section and pushing it into the other side along its length. The snap on strips are butted together to form a joint in ExoTec Top Hat section without any sealant.

The ExoTec Gasket Snap Strip is a hi-tensile roll-formed steel section with rubber gaskets fitted in it on both sides. It gets compressed under the panel edges and provides a primary weathertightness at the vertical joint. See Figure 7.

A vertical joint up to 20mm in width can be formed. It must be ensured that the panel edges cover the rubber gasket fitted on either side of ExoTec Gasket Snap Strip. The vertical joints can be staggered to achieve a brick layout pattern. See Figures 1 and 2.

Note: The vertical joint must always be formed over the ExoTec Top Hat section.

6.3 HORIZONTAL PANEL JOINTS

Horizontal joints are formed using Aluminium 'T' socket or a 'Z' flashing. The Aluminium 'T' Socket is bonded to the rear top edge of panels using a polyurethane adhesive sealant e.g. Seal 'N' Flex-1 by Bostik, Sikaflex 11FC by Sika or similar. The lower edge of upper panel above the joint is also sealed and laps over the upstand of Aluminium 'T' Socket. Refer to Figure 19 and 20. The 'T' Socket is a 1.2mm thick aluminium extruded section.

The fixings along the horizontal panel edges must not penetrate through the Aluminium 'T' Socket.

Aluminium 'T' Socket must be sealed to the ExoTec Top Hat section at their intersection point as shown in Figures 20 and 21 to stop moisture penetration behind the 'T' Socket.

Where a vertical panel joint terminates over the horizontal joint, the 'T' Socket is also sealed to the face of ExoTec Gasket Snap Strip. Refer to Figures 22 and 23.

6.4 JOINTING IN VERY HIGH WIND PRESSURE

For design wind pressures including and above 4.0kPa, horizontal and vertical joints must be continuously sealed with a suitable flexible and paintable joint sealant e.g. Fosroc SilaFlex MS, Seal 'N' Flex-1 or similar. Refer to Figure 8.

Note: When using a horizontal 'Z' flashing, the horizontal joints must not be sealed. Seal the butt joint.

Refer to sealant manufacturers instructions for application and painting.

6.5 FLASHING OVERLAPS

When using 'Z' flashings at horizontal joints or cap flashings on top of walls etc. Refer to Table 5 for the minimum lap required over the cladding. Refer to Figure 22.

Table 5

Minimum flashing overlaps			
Maximum Design Wind Pressure (kPa ULS) up to	1.5	2.5	5.0
Minimum Flashing Cover (mm)	35	50	75

6.6 MOVEMENT JOINTS

Movement joints are required to limit or remove stresses transferred to panels due to the movement/deflections experienced in framing.

6.6.1 VERTICAL STRUCTURAL JOINTS

Where vertical structural joints are provided in a building to accommodate for structural movement, the vertical joints in ExoTec Facade Panel must coincide with these structural vertical joints. The vertical structural joint is constructed as shown in Figure 25. The project engineer is responsible for specifying the locations of vertical structural joints

For panel abutting into masonry/concrete wall see Figures 26 and 27.

6.6.2 HORIZONTAL STRUCTURAL JOINTS

Horizontal structural joints are required at floor/slab level where the framing supporting the ExoTec Top Hat can move due to creep/deflection in the slab. Refer to Figure 24 for a suitable detail for horizontal deflection. See Table 5 for the flashing overlaps required.

Note: The project engineer is responsible for specifying the amount of anticipated movement/deflection.

7 Junctions

7.1 SLAB JUNCTIONS

When jointing two different building materials the different expansion and contraction rates of the materials must be considered.

7.2 HEAD

Where ExoTec Facade Panel butts into an exposed slab, the detail must allow for sufficient creep/deflection expected in the slab. Refer to Clause 6.6.2 for creep/deflection where ExoTec Top Hat crosses in front of the slab.

Refer to Figure 27 for typical detail, which can cater for this deflection.

7.3 BASE

ExoTec Base Mould is fitted at the rainscreen cavity base to allow for moisture drainage and ventilation required for the cavity. In a soffit application the base mould must lap under the RAB Board/building wrap or the base mould upstand must be taped to the RAB Board/building wrap to transfer the moisture to the exterior. Refer to Figure 18.

Note: It is essential that a continuous base mould flashing is provided behind the ExoTec Facade Panel at the base of the facade to allow for drainage/ventilation and to form vermin proofing.

7.4 SOFFIT JUNCTION

There are many ways of detailing the soffit junction and it is important to ensure that 15mm minimum drip edge is formed.

A typical method to install a soffit fascia junction is shown in Figure 18. Ensure the ExoTec Base Mould is fitted at the bottom of facade cavity.

7.5 ABUTMENTS

There are different methods of finishing panels against another cladding system. A typical detail is shown in Figure 26.

8 Corners

An external/internal corner is constructed using ExoTec Top Hat Corner Flashing in the corner fitted over ExoTec Intermediate Top Hat section on one side and to ExoTec Facade Panel on the other side. Refer to Figures 11, 12 and 13.

When a corner with a small radius is required, it can be made using a purpose made metal flashing or a Glass Reinforcement Cement (GRC) to suit the site requirements and is supplied by other manufacturers.

Note: The ExoTec Intermediate Top Hat section behind the corner flashing can be omitted when suitable framing is not available in the corner to fix Top Hat section.

9 Windows

The ExoTec Facade Panel Top Hat Rainscreen system provides an opportunity to consider a wide range of alternative window opening treatments. The specifier/designer, in conjunction with the window manufacturer, must consider to achieve an effective weatherproofing of the window/door openings. Also, refer to moisture management requirements in Clause 2.5 for further information.

The typical generic window details are shown in Figures 14, 15, 16 and 17.

10 Special details

10.1 CURVED FACADES

Where the curve radius is 10m or greater, ExoTec Facade Panel can be bent to suit the curve of the framing. Refer to Table 6 for maximum ExoTec Top Hat spacing.

Table 6

Maximum ExoTec Top Hat spacing for curved applications	
RADII (M)	MAX EXOTEC TOP HAT SPACING (MM)
10 to 15	400
>15	600 max. or to suit wind pressures as per Table 1

Notes:

1. ExoTec Facade Panel must be fixed horizontally to the ExoTec Top Hat sections.
2. The closer the spacing of ExoTec Top Hats, the less likely they will read through the panels, particularly at small radii.
3. In curved applications, always commence fixing of panels from the centre and work outwards to avoid "drumminess".

10.2 PARAPET CAPPING

The design of the metal parapet capping should aim to provide weathertightness and minimise the staining of cladding. Follow the following recommendations;

1. The flashing must overlap the cladding by a minimum distance as specified in Table 5.
2. Ensure the parapet capping has a slope towards the roof.
3. Provide a drip edge away from the cladding face.
4. In addition, cappings must be lapped at a junction as per the Table 7 below and all joints in capping should be sealed. Refer to Table 7 for the required joint overlap,

Table 7

Parapet capping joint overlap			
Max. Design Wind Pressure Up to (kPa ULS)	2.0	3.5	5.0
Min. Capping Overlap (mm)	50	100	150

Note: For permissible design wind pressure, divide ULS wind pressure by 1.5.

10.3 INSPECTION

After the installation of ExoTec Facade Panels and before the painting, the facade/fascia should be inspected to ensure:

1. Required number and location of fixings are correct.
2. Sealant is applied where specified.
3. The epoxy fillers is filled in the screw holes and sanded smooth to finish flush with panel surface.
4. Minor damage to panel edges can be filled with epoxy, sanded smooth and painted, see Section 11.

11 Finishes

11.1 GENERAL

To ensure the durability of ExoTec Facade Panels, as per Clause 14.5 the panels must be finished as indicated below. The panels must be painted within 90 days of installation.

ExoTec Facade Panels will readily accept a wide variety of applied finishes, including site applied coatings and the factory applied special finishes.

For site-applied finishes (acrylic coatings), follow the paint manufacturer's recommendations. It is recommended that the paints with a minimum dft 150 micron be used.

All site cut edges or sanded patches on panel surface must be primed after cutting or sanding. The face and edges of the panels must be coated in accordance with the paint manufacturer's recommendations. Also refer to Clause 5.3.

For further information, contact the customer service centre of the relevant paint company.

Polyurethane paints are not suitable as a site-applied finish but can be factory coated prior to installation. Pre-finished panels are generally installed using exposed head fasteners coated in the same colour.

11.2 PANELS EXPOSED TO DIRECT SUNLIGHT

The primed face or rear of the panels must not be exposed to direct sunlight for any period greater than three months. The face must be over-coated with a suitable primer as recommended by the paint manufacturer. However, if the rear clear sealer is to be

exposed to direct sunlight by its application, e.g. fascias, plant rooms, etc. then the clear sealer must be coated with a minimum of one coat of an exterior grade acrylic, pigmented white.

12 Storage and handling

All materials should be stored to avoid damage, with edges and corners of the panels protected from chipping.

ExoTec Facade Panels must be protected from rain during transport and storage. The panels and ExoTec Top Hat sections must be laid flat undercover on a smooth level surface clear of the ground to avoid exposure to water or moisture etc. ExoTec Facade Panels and ExoTec Top Hat sections are resistant to permanent water damage when installed as directed. The panels must only be installed in a dry state.

When handling ExoTec Facade Panels, carry panels on the edge taking care not to chip edges and corners.

Refer to the Clause 15 for recommended Safe Working Practices.

ExoTec Top Hat sections and other metal accessories must be handled with utmost care during transportation and at sites to avoid any personal injuries and to achieve the best possible panel flatness.

ExoTec Top Hat sections and metal accessories must be handled while wearing gloves.

13 Maintenance

It is the responsibility of the specifier to determine normal maintenance requirements to maintain the effectiveness of the cladding. The extent and nature of maintenance required will depend on the geographical location and exposure of the building.

As a guide, it is recommended that the basic normal maintenance tasks shall include, but not be limited to:

- Washing down exterior surfaces every 6-12 months*.
- Re-coating exterior protective finishes**.
- Regular inspection and repair if necessary of ExoTec Facade Panels, sealants etc.
- Cleaning out gutters, down pipes and overflow pipes as required.
- Pruning back vegetation which is close to or touching the building as well as ensuring the NZBC ground clearance requirements are maintained especially where gardens are concerned.
- The clearance between the bottom edge of ExoTec Facade Panel and the finished/unfinished ground must always be maintained.

- Refilling the countersunk holes where the cracks start appearing in the paint film around epoxy fillers or where fastener head through becomes significant.

*Do not use a water blaster to wash down the cladding.

**Refer to the paint manufacturer for washing down and recoating requirements related to ongoing paint performance.

14 Product information

14.1 MANUFACTURING AND CLASSIFICATION

ExoTec Facade Panels are high quality compressed, autoclaved, cement based building panels manufactured by James Hardie. RAB Board is a medium density autoclaved cellulose fibre reinforced cement based building product.

The basic composition of these products is Portland cement, sand, cellulose fibre and water. These products are identified by the name printed at regular intervals on the back face.

James Hardie building products are manufactured to Australian/ New Zealand Standard AS/NZS 2908.2 'Cellulose-Cement Products' (ISO 8336 'Fibre-Cement Flat Sheet'). James Hardie New Zealand is an ISO 9001 'Telarc' certified manufacturer.

ExoTec Facade Panel is classified Type A, Category 3 in accordance with AS/NZS 2908.2 (ISO 8336).

14.2 PRODUCT MASS

The nominal density of ExoTec Facade Panel is 1552kg/m³ at EMC.

The nominal density of RAB Board is 1300kg/m³. For panel sizes, see Clause 14.3 and 14.4 Section 16.

14.3 EXOTEC FACADE PANEL

ExoTec Facade Panel is manufactured to have the nominal sizes as outlined in Table 8 below.

Table 8

ExoTec Facade Panel properties	
PROPERTIES	EQUILIBRIUM CONDITION
Width	1190mm
Length	2400mm or 3000mm
Approx. Mass	17 kg/m ²

14.4 RAB BOARD

RAB Board is manufactured to have the properties and sizes as outlined in Table 9 below.

Table 9

RAB™ Board properties	
PROPERTIES	EMC CONDITION
Width	1200mm
Length	2400, 3000mm
App. Mass	-8.5 kg/m ²

14.5 DURABILITY

ExoTec Facade Panels and RAB Board, when installed and maintained as per this technical specification, will meet the durability requirements of 'Durability' Clause B2 of NZBC.

14.6 RESISTANCE TO MOISTURE/ROTTING

ExoTec Facade Panel has demonstrated resistance to permanent moisture induced deterioration (rotting) and has passed the following tests in accordance with AS/NZS 2908.2

- Water Permeability (Clause 8.2.2)
- Warm Water (Clause 8.2.4)
- Heat Rain (Clause 6.5)
- Soak Dry (Clause 8.2.5)

14.7 RESISTANCE TO FIRE

ExoTec Facade Panel is deemed to be a non-combustible material in accordance with AS1530 Part 1. The panel has been tested by CSIRO and has the following Early Fire Hazard Indices (tested to AS 1530 Part 3).

Early fire hazard indices	
Flammability (FI)	0
Spread of Flame Index (SFI)	0
Heat Evolved Index	0
Smoke Developed Index (SDI)	0 – 1

14.8 ALPINE REGIONS

In regions subject to freeze/thaw conditions, ExoTec Facade Panel must not be in direct contact with snow and/or ice build up, e.g. external walls in alpine regions subject to snowdrifts over winter.

ExoTec Facade Panel and RAB Board have been tested for resistance to frost in accordance with AS/NZS 2908.2 Clause 8.2.3.

15 Safe working practice

WARNING — DO NOT BREATHE DUST AND CUT ONLY IN WELL VENTILATED AREA

James Hardie products contain sand, a source of respirable crystalline silica which is considered by some international authorities to be a cause of cancer from some occupational sources. Breathing excessive amounts of respirable silica dust can also cause a disabling and potentially fatal lung disease called silicosis, and has been linked with other diseases. Some studies suggest smoking may increase these risks. During installation or handling: (1) work in outdoor areas with ample ventilation; (2) minimise dust when cutting by using either 'Score and Snap' knife, fibre cement shears or, where not feasible, use a HardieBlade™ Saw Blade and dust-reducing circular saw attached to a HEPA vacuum; (3) warn others in the immediate area to avoid breathing dust; (4) wear a properly-fitted, approved dust mask or respirator (e.g. P1 or P2) in accordance with applicable government regulations and manufacturer instructions to further limit respirable silica exposures. During clean-up, use HEPA vacuums or wet cleanup methods — never dry sweep. For further information, refer to our installation instructions and Material Safety Data Sheets available at www.jameshardie.co.nz

Failure to adhere to our warnings, material safety data sheets, and installation instructions may lead to serious personal injury or death.

James Hardie recommended safe working practices

CUTTING OUTDOORS

1. Position cutting station so that wind will blow dust away from user or others in working area.
2. Use a dust reducing circular saw equipped with HardieBlade™ Saw Blade and HEPA vacuum extraction

SANDING/DRILLING/OTHER MACHINING

When sanding, drilling or machining you should always wear a P1 or P2 dust mask and warn others in the immediate area.

IMPORTANT NOTES:

1. NEVER use a power saw indoors
2. NEVER use a circular saw blade that does not carry the HardieBlade™ logo
3. NEVER dry sweep – Use wet suppression or HEPA Vacuum
4. NEVER use grinders
5. ALWAYS follow tool manufacturer's safety recommendations

P1 or P2 respirators can be used in conjunction with above cutting practices to further reduce dust exposures. Additional exposure information is available at www.jameshardie.co.nz to help you determine the most appropriate cutting method for your job requirements. If concern still exists about exposure levels or you do not comply with the above practices, you should always consult a qualified industrial hygienist or contact James Hardie for further information.

15.1.1 WORKING INSTRUCTIONS

Refer to Recommended Safe Working Practices before starting any cutting or machining of product.

15.1.2 HARDIEBLADE™ SAW BLADE

The HardieBlade™ Saw Blade used with a dust-reducing saw fitted with HEPA vacuum filter is ideal for fast, clean cutting of James Hardie fibre cement products. A dust-reducing saw uses a dust deflector or a dust collector connected to a vacuum system. When sawing, clamp a straight-edge to the sheet as a guide and run the saw base plate along the straight edge when making the cut.

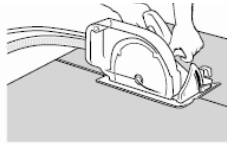

15.1.3 HOLE-FORMING

For smooth clean cut circular holes:

Mark the centre of the hole on the panel.
Pre-drill a 'pilot' hole.

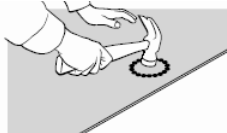

Using the pilot hole as a guide, cut the hole to the appropriate diameter with a hole saw fitted to a heavy duty electric drill.

For irregular holes:

Small rectangular or circular holes can be cut by drilling a series of small holes around the perimeter of the hole then tapping out the waste piece from the sheet face. Tap carefully to avoid damage to panel, ensuring that the panel edges are properly supported.

15.1.4 HANDLING AND STORAGE

All materials should be stored to avoid damage, with edges and corners of the panels protected from chipping.

ExoTec Facade Panels and ExoTec Top Hat sections must be protected from rain during transport and storage. They must be laid flat undercover on a smooth level surface clear of the ground to avoid exposure to water or moisture etc. ExoTec Facade Panel and RAB Board are resistant to permanent water damage when installed as directed, and must only be installed in a dry state. When handling ExoTec Facade Panel and RAB Board, carry panels on the edge taking care not to chip edges and corners.



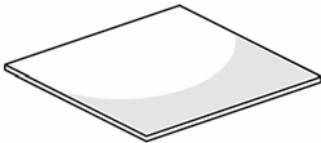
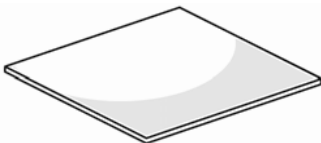

15.1.5 QUALITY

James Hardie conducts stringent quality checks to ensure that any product manufactured falls within our quality spectrum. It is the responsibility of the builder to ensure that the product meets aesthetic requirements before installation. James Hardie will not be responsible for rectifying obvious aesthetic surface variations following installation.

16 Product and accessories

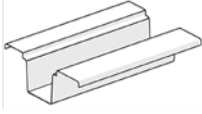
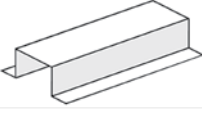
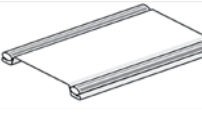

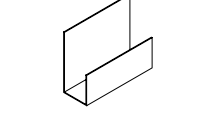
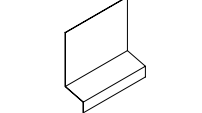
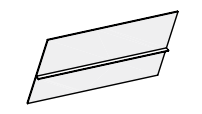

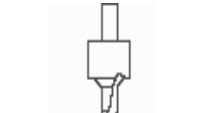

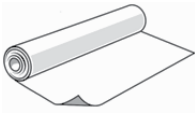

ExoTec Facade Panel information			
PRODUCT	DESCRIPTION	SIZE	
			ExoTec Facade Panel Dense compressed panel. Square edge. Factory sealed on all six sides. Each panel has a distinctive white face, which accepts a wide range of paint finishes. The panel must be installed with the white side facing the exterior of the structure.
			1190MM WIDTH
		2400	✓
		3000	✓
			SAP CODE
			402282
			402284
	RAB Board Used as rigid air barrier behind the building facades. The green surface is fixed facing the cavity.	LENGTH (MM)	RAB BOARD 6MM
			1200MM WIDTH
		2400	✓
		3000	✓
			SAP CODE
			402980
			402981

Accessories supplied by James Hardie

ACCESSORIES	DESCRIPTION	QUANTITY/SIZE (APPROX)
	<p>ExoTec Top Hat Proprietary rolled zincaluminum coated AZ150 steel sections 124mm wide x 35mm deep x 1.15mm thick. Designed to span vertically across the building structure to support the panels along vertical panel joints and isolate movement of the panels from those of the structure.</p>	<p>4800mm lengths Code: 304580</p>
	<p>ExoTec Intermediate Top Hat Rolled zincaluminum coated AZ150 steel sections 50mm wide x 35mm deep x 1.15mm thick, designed to span vertically across the building support structures and to be used as intermediate support to the panels.</p>	<p>4800mm length Code: 304581</p>
	<p>ExoTec Gasket Snap Strip Black sealing Neoprene Gaskets. Specially designed to clip into the ExoTec Top Hat at vertical sheet joints to cover fixings to the structure and to provide an initial weather seal and drainage.</p>	<p>4800mm length Code: 304582</p>
	<p>ExoTec Top Hat Corner Flashing Pressed metal zinc aluminum coated Section 0.95mm thick. Used in internal and external corner details.</p>	<p>3000mm length Code: 304661</p>
	<p>ExoTec Top Hat J Mould Used at butt joints with other materials like concrete or masonry.</p>	<p>3000mm length Code: 304662</p>
	<p>ExoTec Top Hat Base Mould To be used to close off the cavity at the base</p>	<p>3000mm length Code: 304663</p>
	<p>Aluminium 'T' Socket 1.2mm thick aluminium extruded etch primed horizontal joint flashing.</p>	<p>2400mm lengths Code: 304105 3000mm lengths Code: 304103</p>
	<p>ExoTec Facade Washer Opaque nylon washer fits beneath the appropriate exposed head fasteners and ExoTec Facade Panels. The ExoTec Facade Washers are fitted in the holes made for fixing the exposed head fasteners.</p>	<p>Pack of 1000 Code: 302761</p>
TOOLS		
	<p>HardieBlade™ Saw Blade Diamond tip 185mm diameter fibre cement circular saw blade. Spacers not included.</p>	<p>Each Code: 300660</p>
	<p>Tungsten Carbide Drill Bit Used for drilling holes for fixing the counter sunk fasteners.</p>	<p>Each Code: 300567</p>

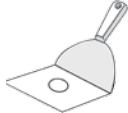
Accessories/tools not supplied by James Hardie

James Hardie recommends the following products for use in conjunction with ExoTec Facade Panel System. James Hardie does not supply these products and does not provide a warranty for their use. Please contact component manufacturer for information on their warranties and further information on their products.

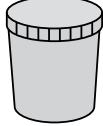
PRODUCT	DESCRIPTION
	Building wrap Must comply with Table 23 of E2/AS1 of NZBC.
	Joint sealing tape Used to seal the vertical joints of RAB Board. e.g. Protecto, Thermakraft or Tyvek®
	Bond breaker tape Used when filling vertical joints to prevent sealant from bonding to top hat.
	6mm masonry drill Used to pre-drill holes for exposed head fasteners.
	Bostik - 'Seal N Flex -1' Adhesive or Sikaflex 11FC adhesive Polyurethane adhesive required to glue the Aluminium 'T' Socket to panels. Can also be used to fill the expressed joints for wind pressures above 4.0kPa.
	Epoxy Flush Sealing (2 Part) Countersunk screw holes are flush sealed using Hilti CA273, Nuplex Fairing Cream or similar epoxy.
	Epoxy Applicator A recommended method of fixing the epoxy over countersunk screw heads. This method minimises the spreading of epoxy over panel surface.
	Flexible tape A flexible self-adhesive tape used in preparation of a window. Refer to the window installation section in this manual for more information. e.g. Protecto, Thermakraft or Tyvek®
FASTENERS	
	Countersunk Fasteners 10g x 30mm countersunk head self drilling screws – Class 4 coating Fasteners must be fully compatible with all other material that it is in contact with to ensure the durability and integrity of assembly. Supplied by EDL Fasteners Code: 34C101630CL4
	Wafer Head/Pan head Fastener 10g x 30mm wafer/pan head screw – Class 4 coating Supplied by EDL Fasteners Code: 34W101630CL4
	Hex Head Screw For fixing ExoTec Top Hat sections into the framing substrate. Refer Table 3 to check design capacity of the fastener required. Chose a fastener suitable to withstand wind pressures. Supplied by EDL Fasteners Code: 34621450NCL4
	Paints and Primers Use Dulux AcraPrime 501/1 primer or Dulux Primercryl to seal the cut edges of panels. Use quality paints only. Refer to manufacturer for further information.

TYVEK® FLEXWRAP™ are trademarks registered to Dupont

17 Details

Various details outlined in the following table are available on Pages 16 to 30.

Details		
DESCRIPTION	FIGURE	PAGE
Horizontal Layout Brick Grid Pattern	Figure 1	19
Vertical Layout Brick Grid Pattern	Figure 2	19
Typical Panel and Framing Layout	Figure 3	20
Wall Base Typical Detail	Figure 4	20
Top Hat and Panel Fixing Detail	Figure 5	21
Countersunk Fastener Detail	Figure 6	21
Vertical Panel Joint Detail	Figure 7	22
Panel Joints in High Wind Pressure Areas Detail	Figure 8	22
Exposed Head Fastener Detail	Figure 9	23
ExoTec Facade Washer Detail	Figure 10	23
Internal Corner Detail	Figure 11	24
External Corner Detail	Figure 12	25
Angled External Corner Detail	Figure 13	26
Commercial Window Sill Detail	Figure 14	27
Commercial Window Jamb Detail	Figure 15	27
Commercial Window Jamb Detail Using 'J' Mould	Figure 16	28
Commercial Window Head Detail	Figure 17	28
Typical Soffit Detail	Figure 18	29
Horizontal Panel Joint Detail at Mid Floor Height	Figure 19	29
Installing Upper Panel Over Aluminium 'T' Socket	Figure 20	30
Sealing Aluminium 'T' Socket to ExoTec Top Hat Section	Figure 21	30
Vertical Joint Terminating over the Horizontal Joint	Figure 22	31
Sealing Aluminium 'T' Socket to ExoTec Top Hat	Figure 23	31
Horizontal Structural Joint Detail	Figure 24	32
Vertical Structural Joint Detail	Figure 25	32
ExoTec Facade Panel and Masonry Wall Abutment Detail	Figure 26	33
Wall Junction Under Concrete Slab Detail	Figure 27	33

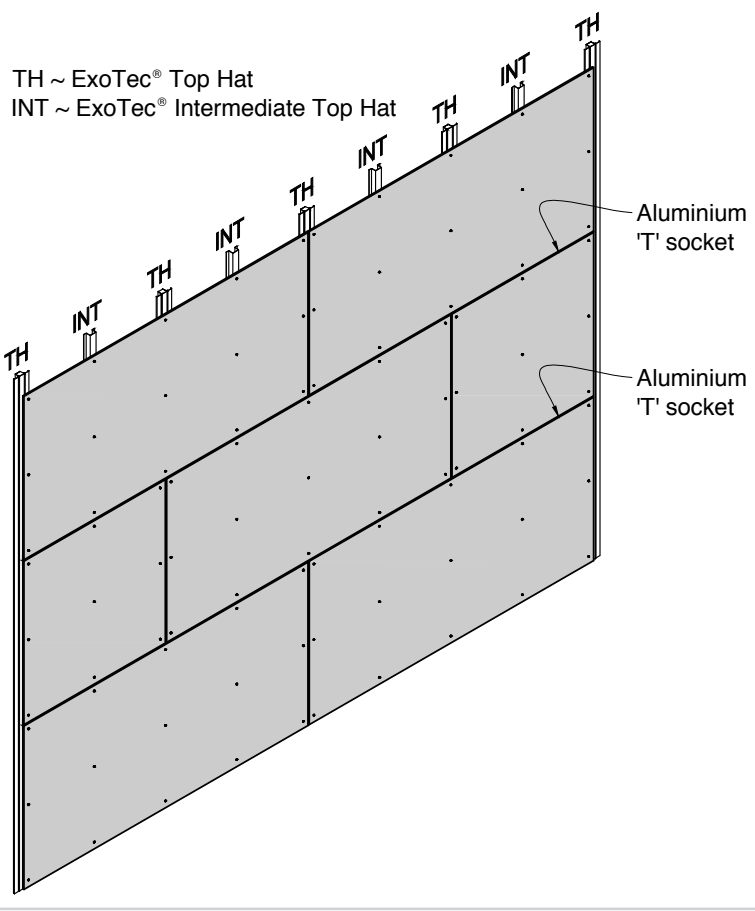

Figure 1: Horizontal layout brick grid pattern

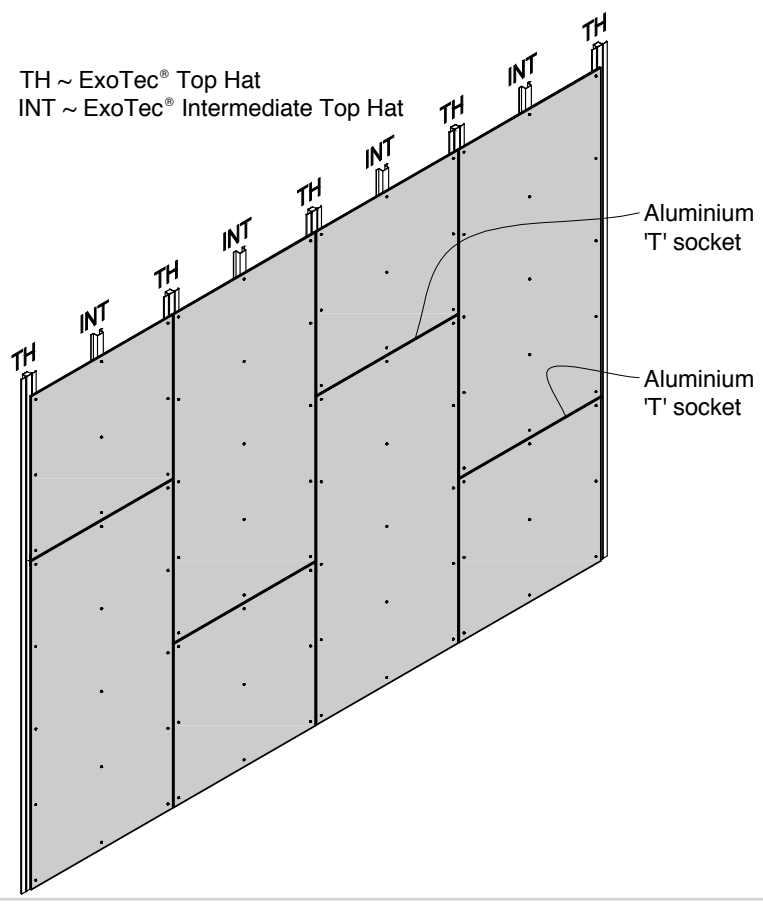

Figure 2: Vertical layout brick grid pattern

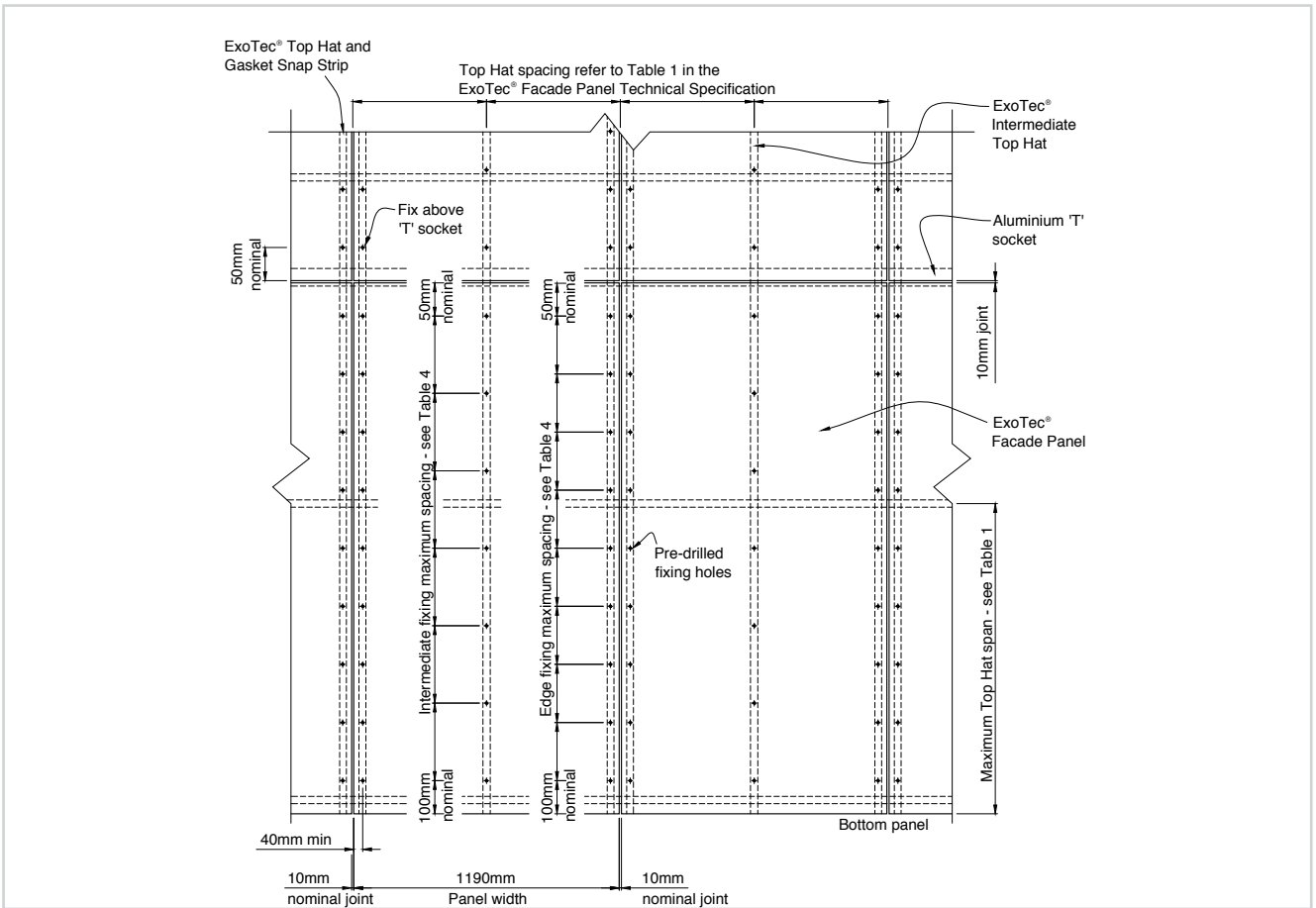

Figure 3: Typical panel and framing layout

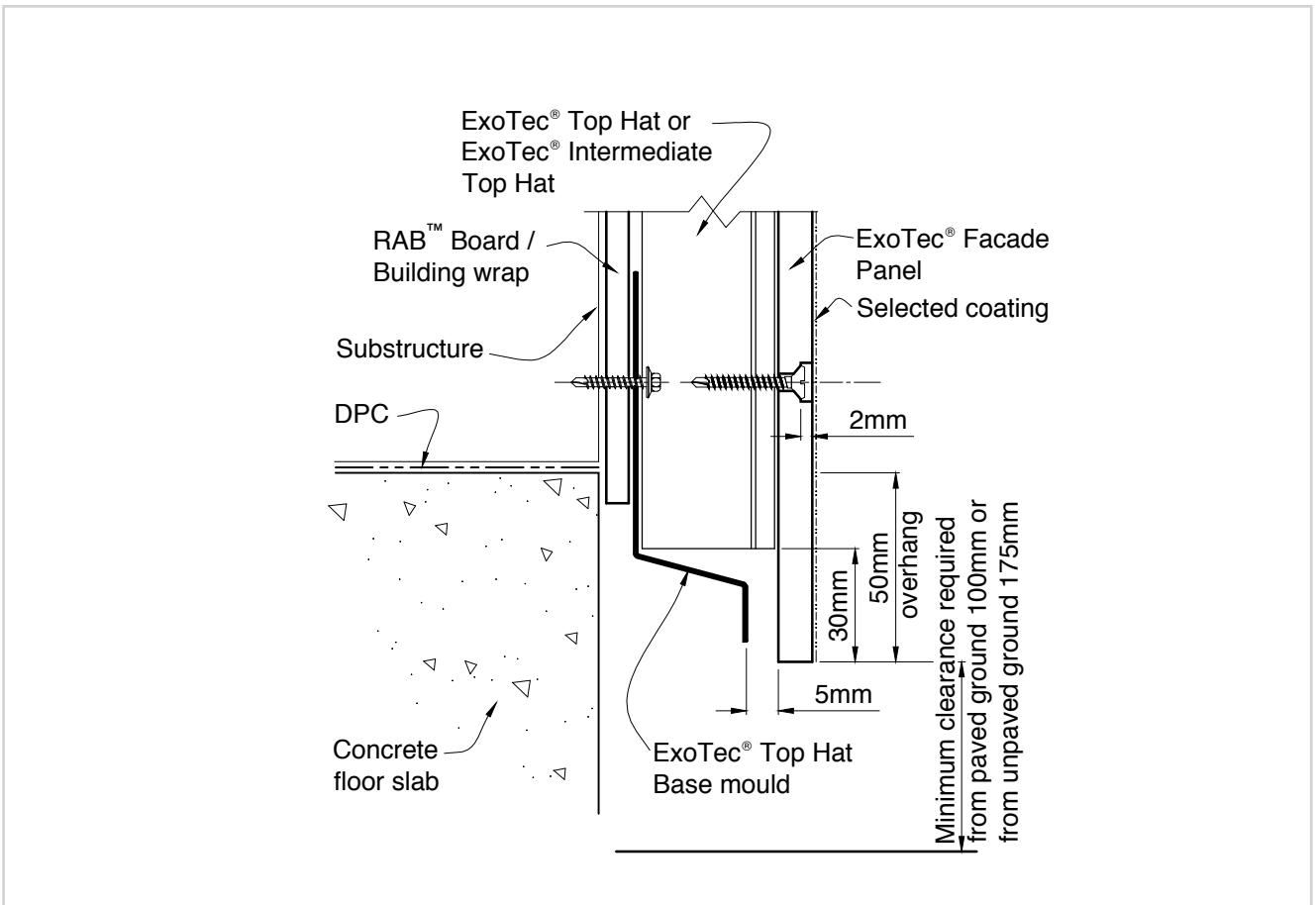

Figure 4: Wall base typical detail

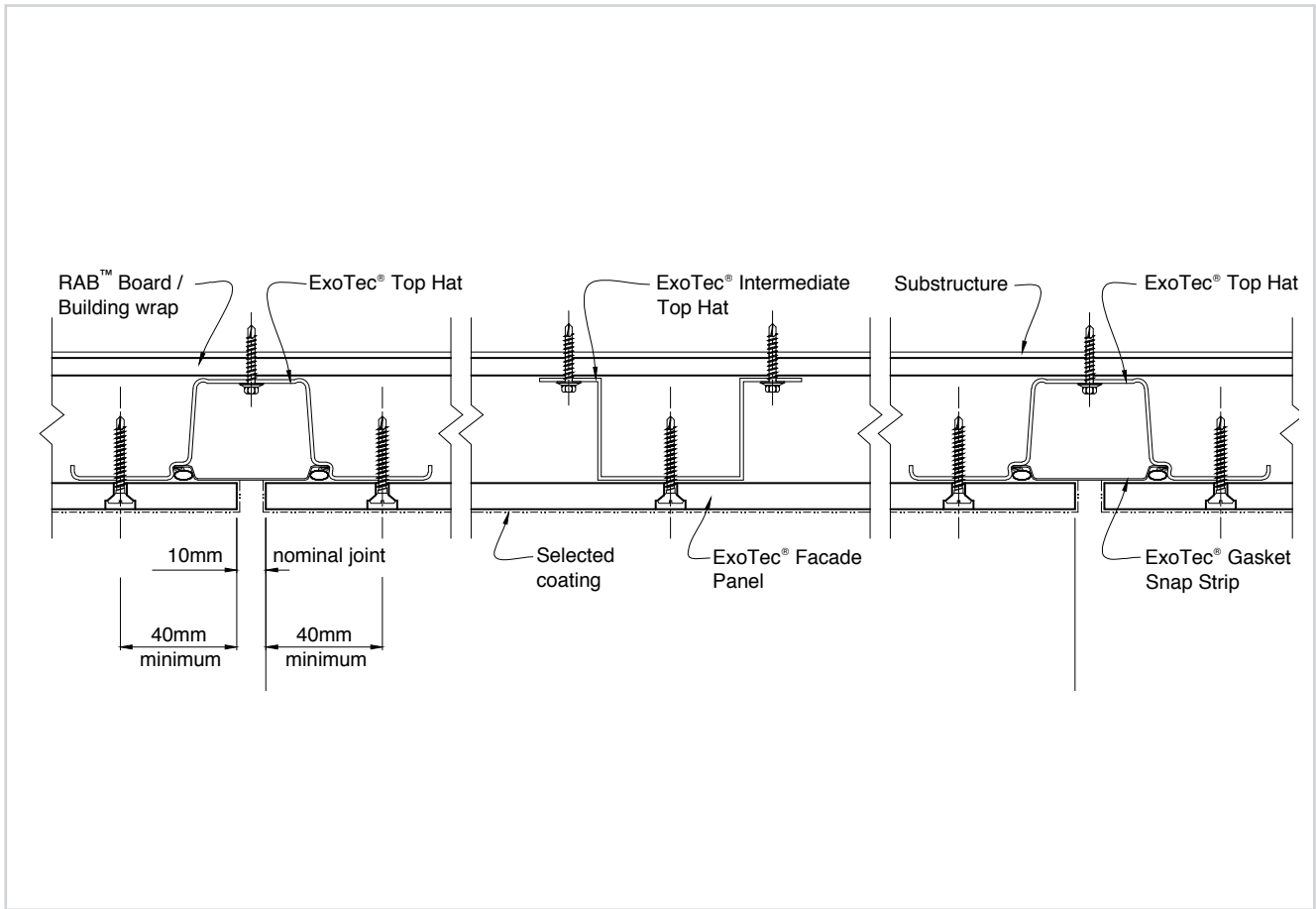

Figure 5: Top Hat and panel fixing detail

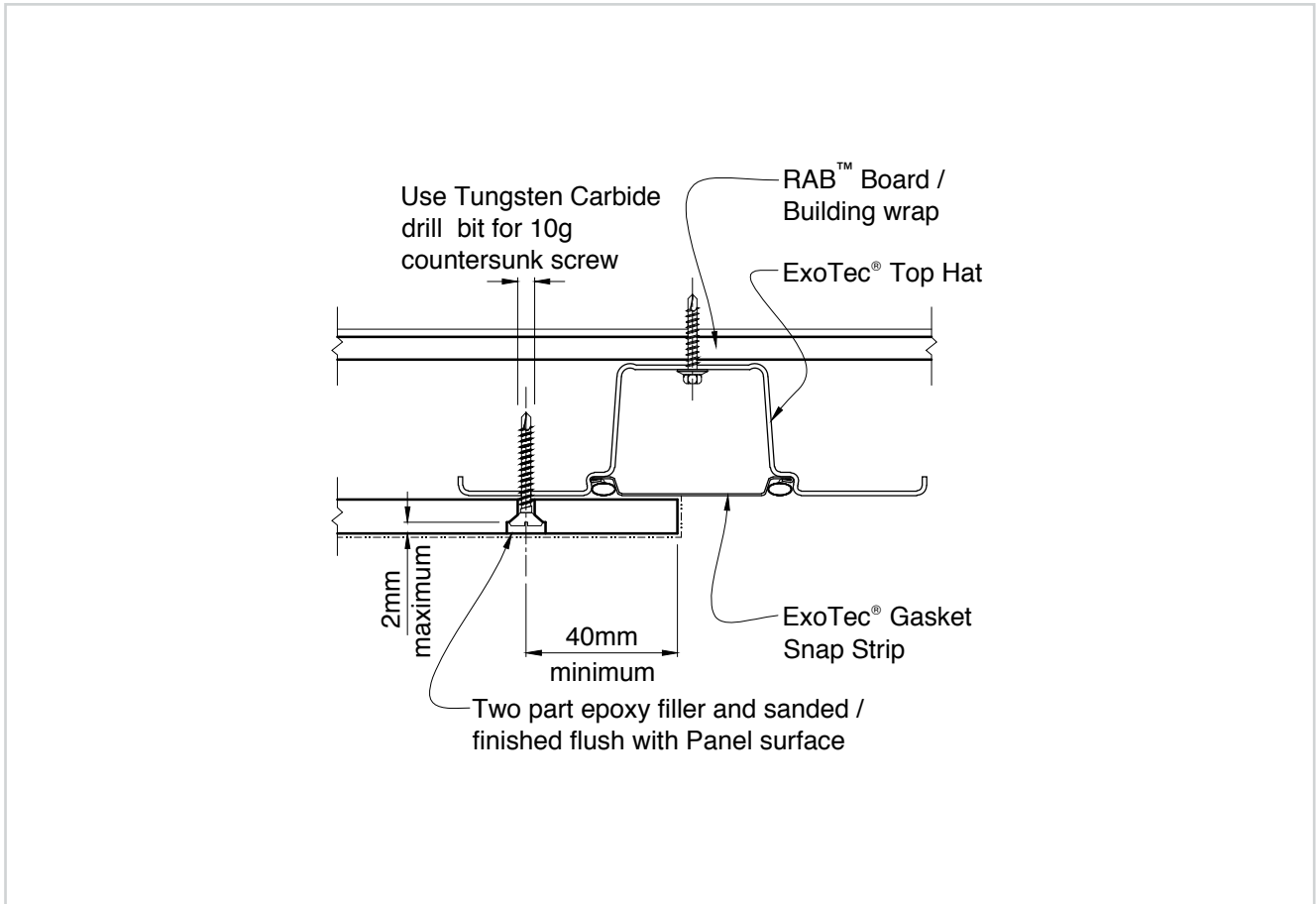

Figure 6: Countersunk fastener detail

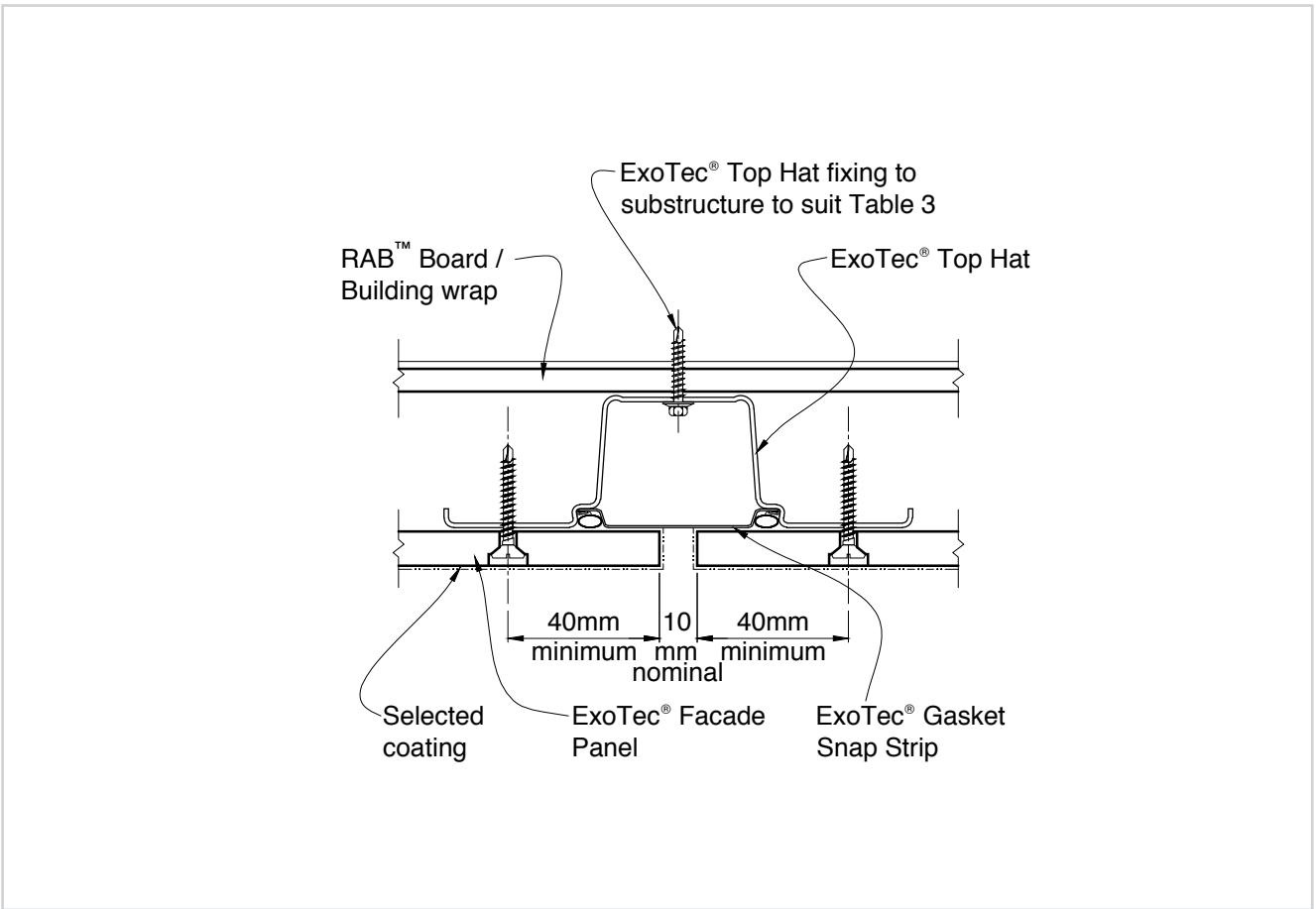

Figure 7: Vertical panel joint detail

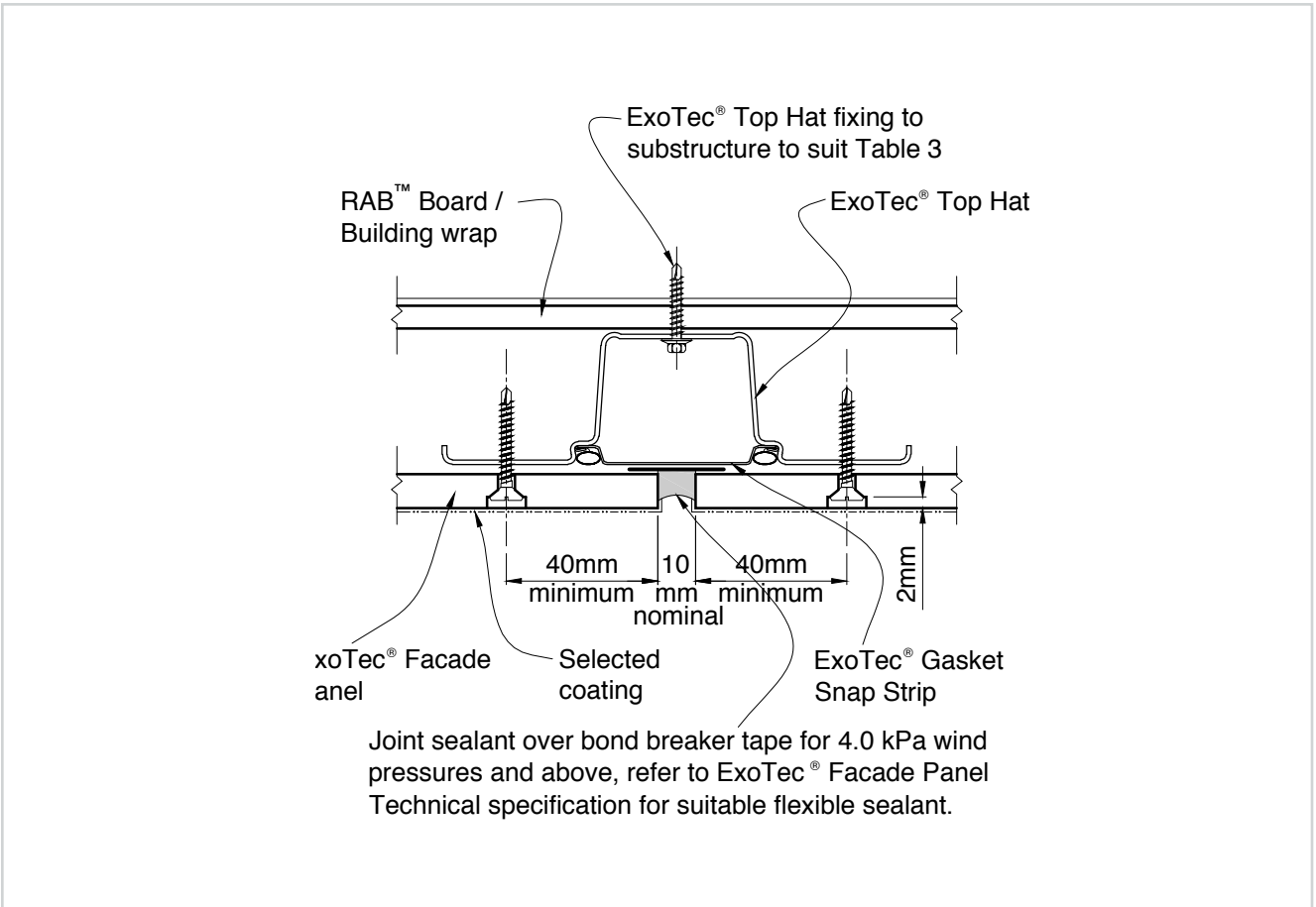

Figure 8: Panel joints in high wind pressure areas detail

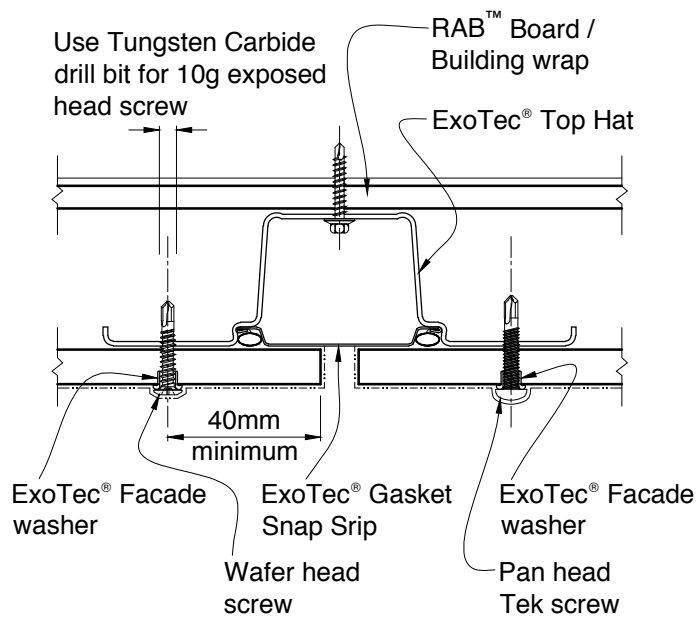

Figure 9: Exposed head fastener detail

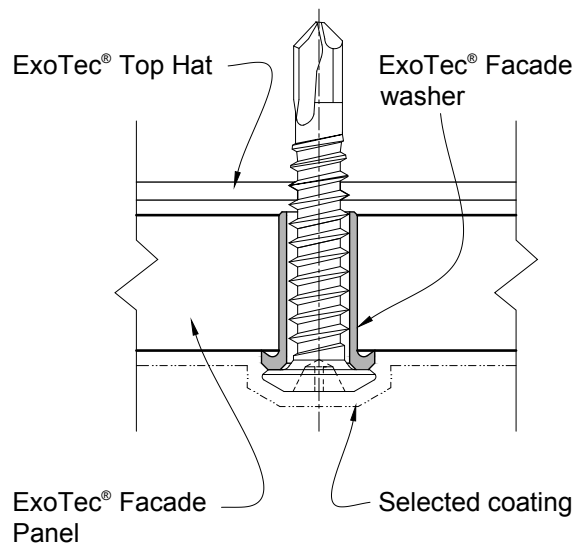

Figure 10: ExoTec Facade washer detail

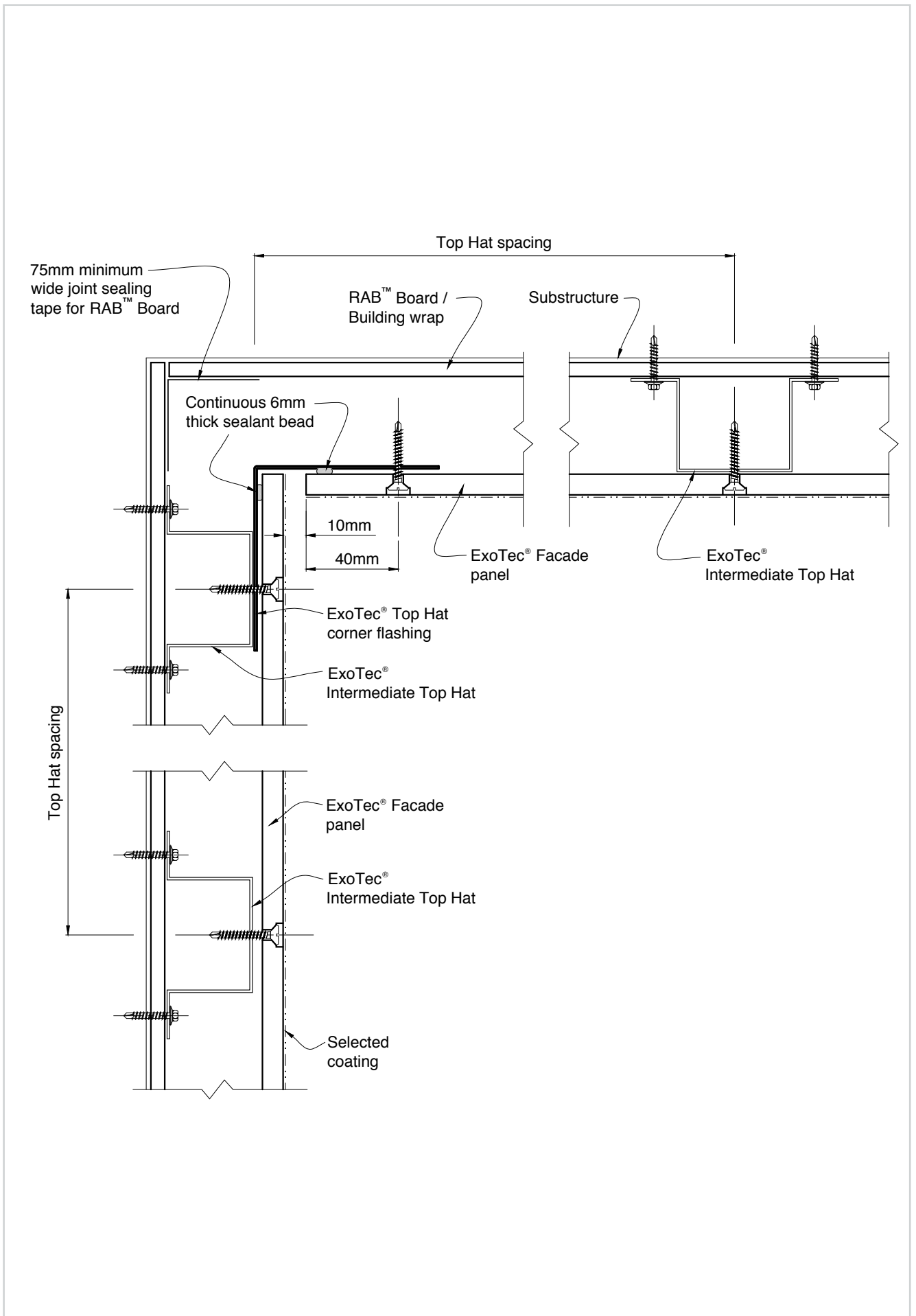

Figure 11: Internal corner detail

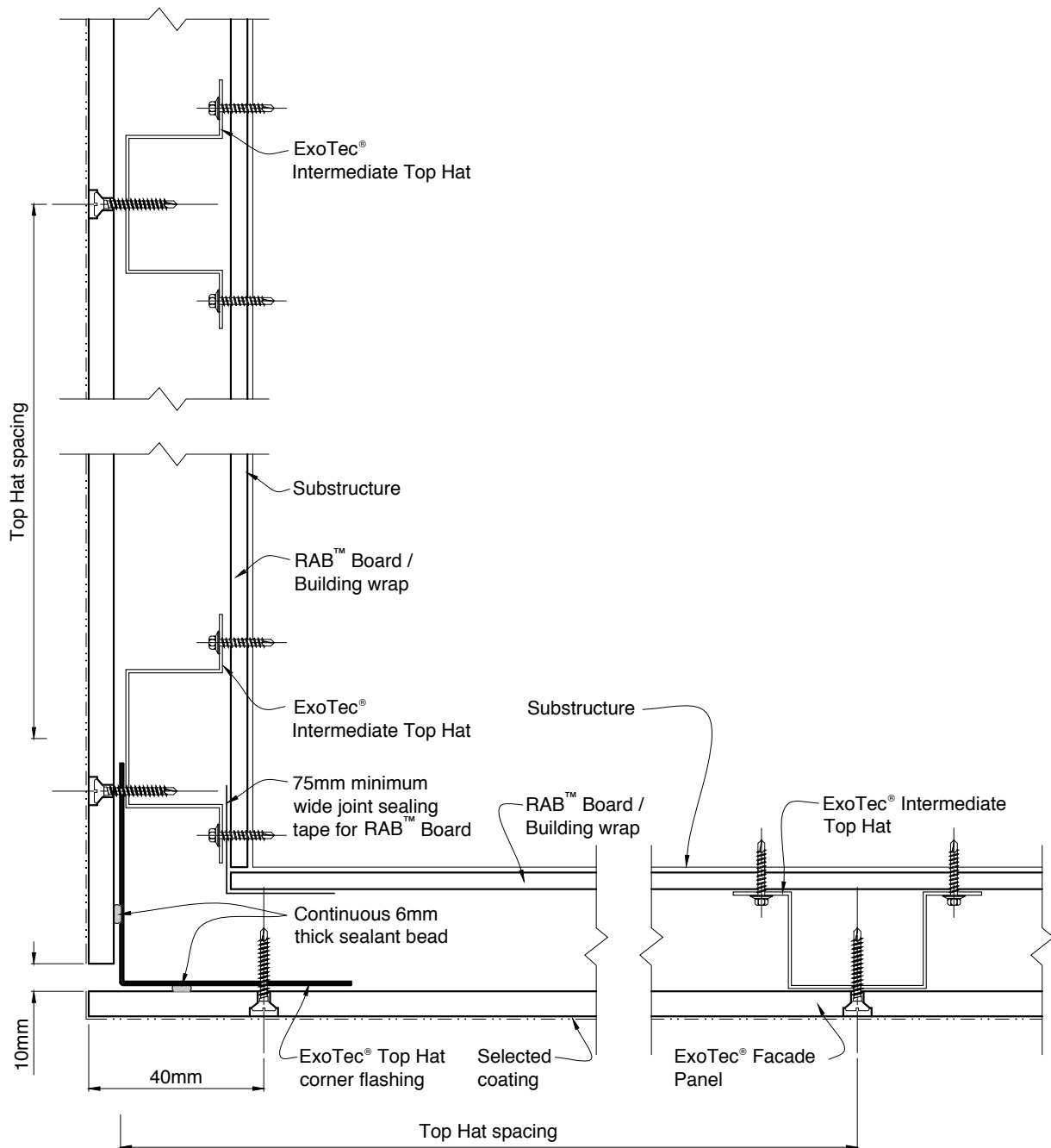

Figure 12: External corner detail

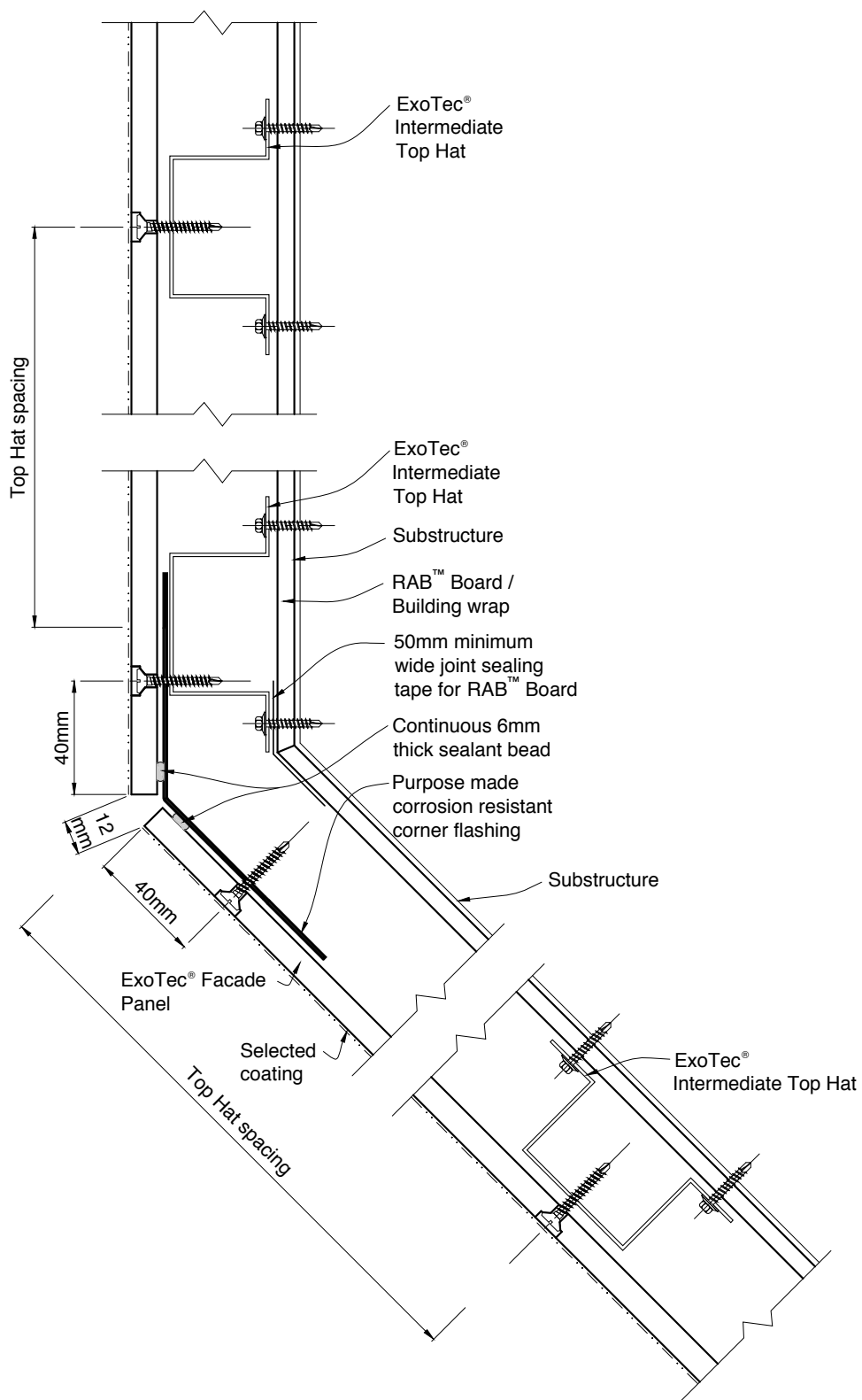

Figure 13: Angled external corner detail

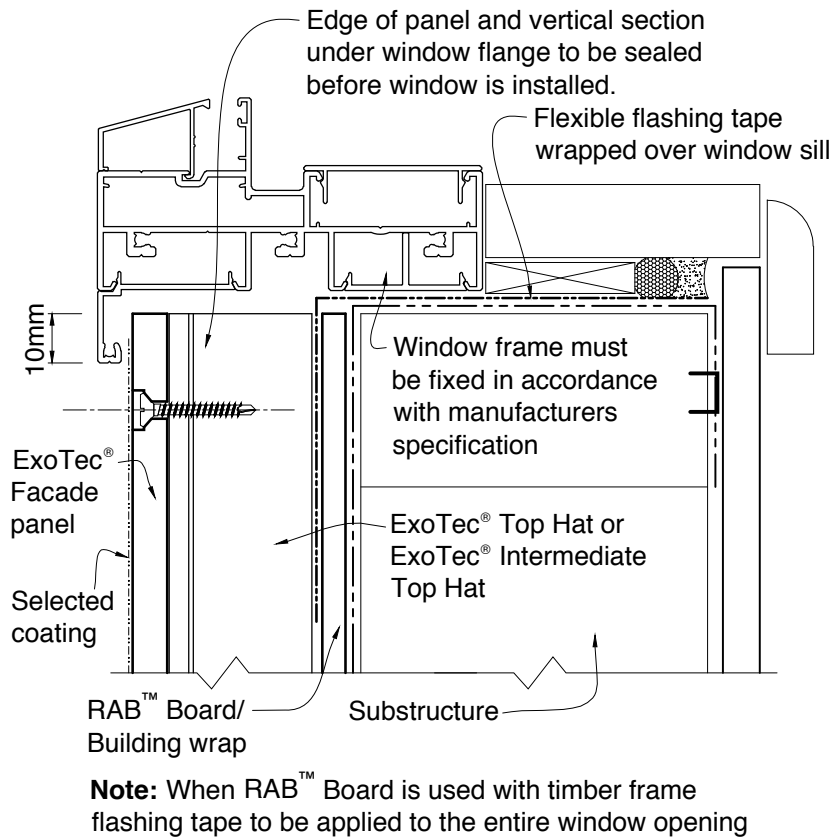

Figure 14: Commercial window sill detail

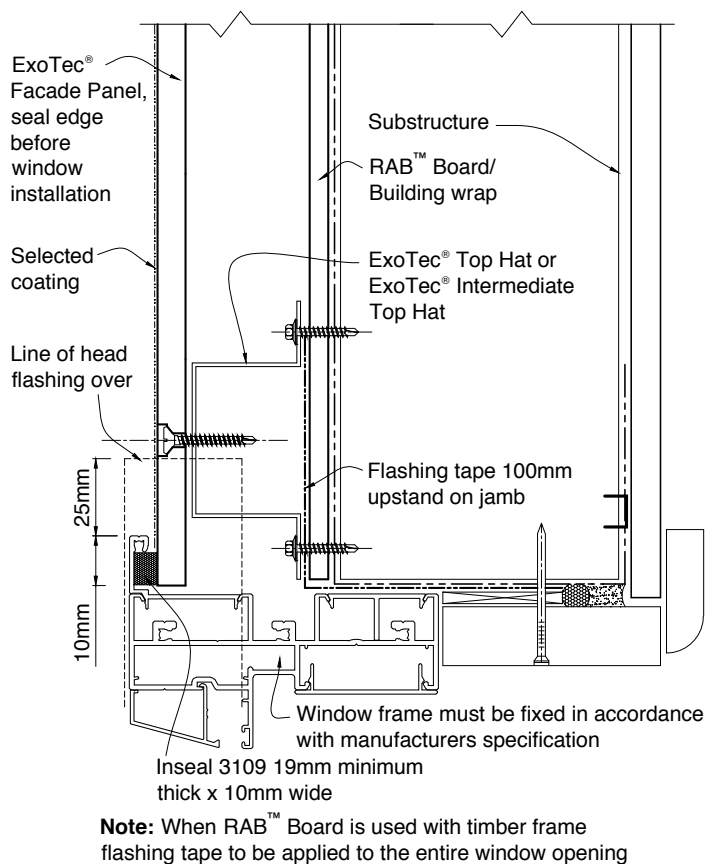

Figure 15: Commercial window jamb detail

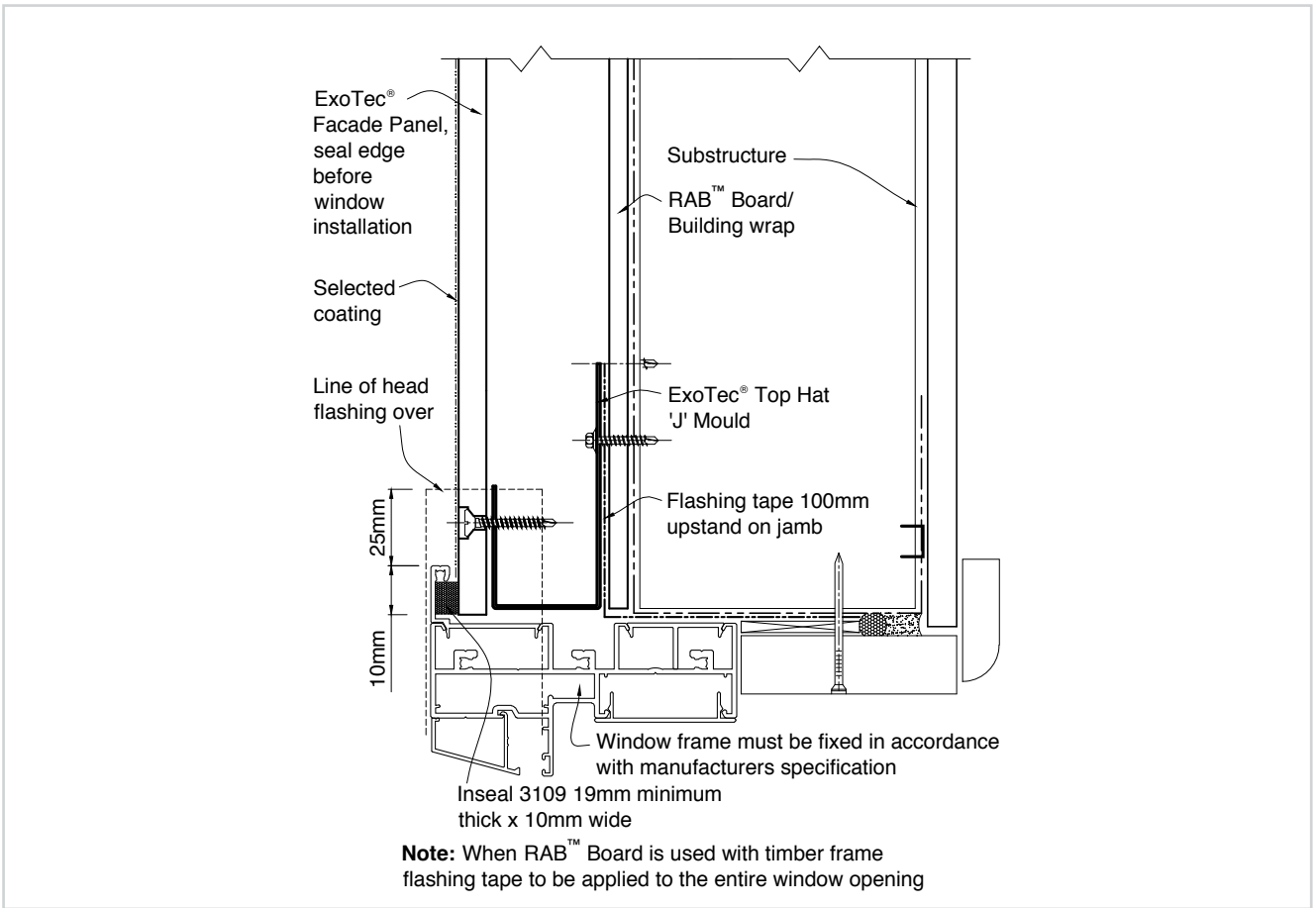

Figure 16: Commercial window jamb detail using 'J' Mould

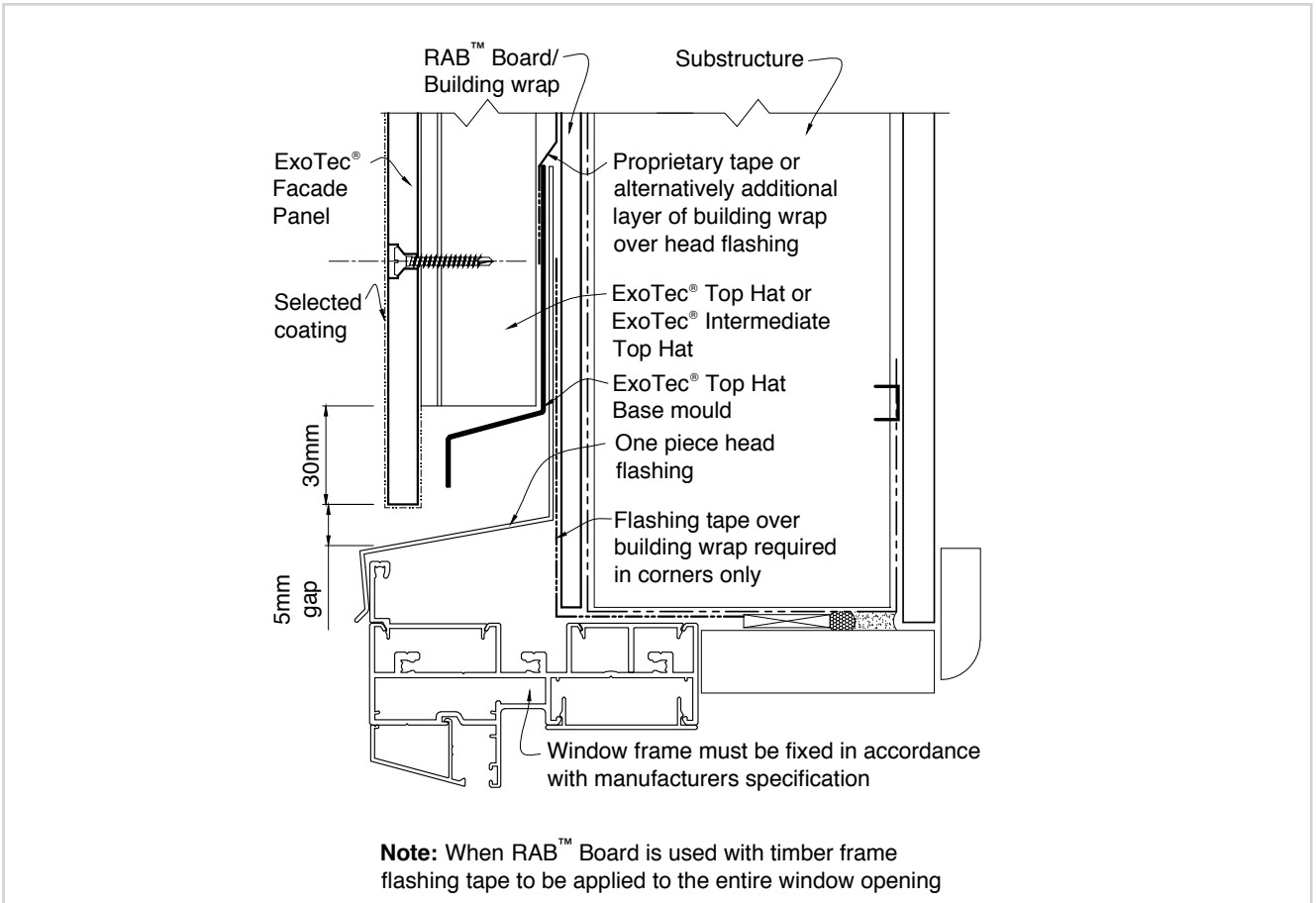

Figure 17: Commercial window head detail

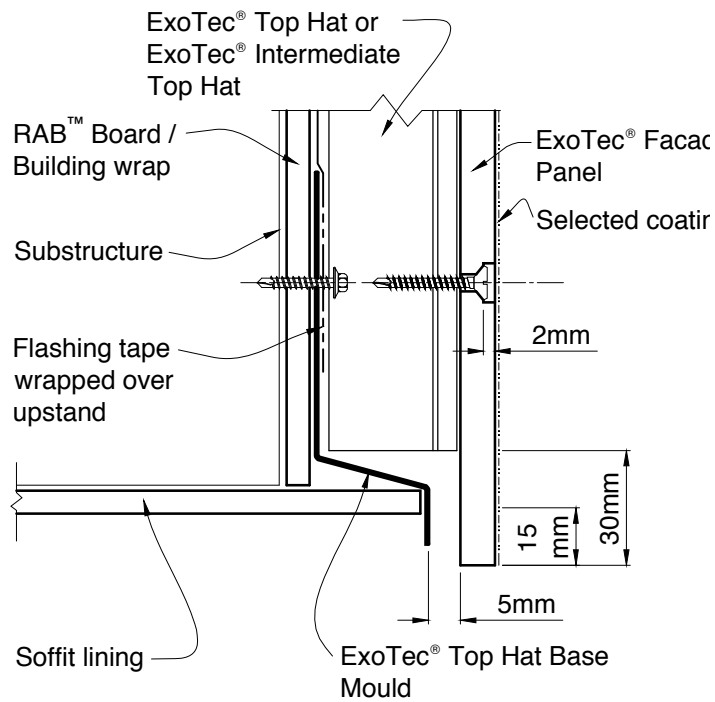

Figure 18: Typical soffit detail

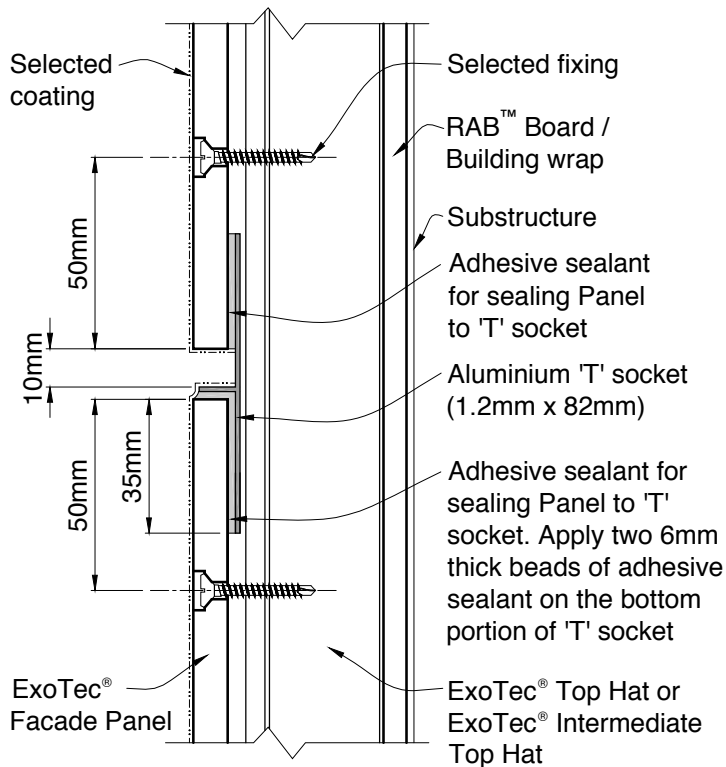

Figure 19: Horizontal panel joint detail at mid floor height

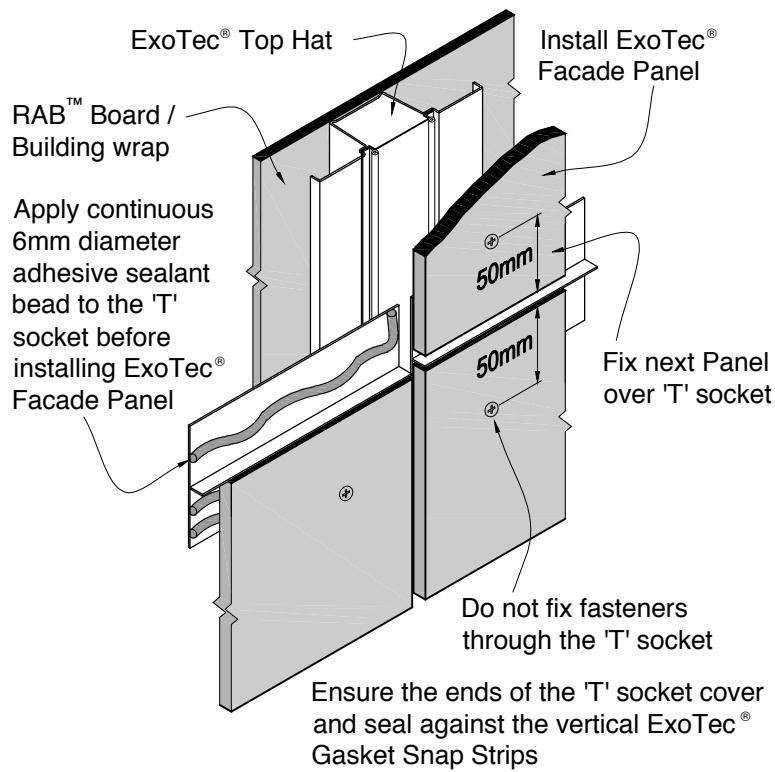

Figure 20: Installing upper panel over aluminium 'T' Socket

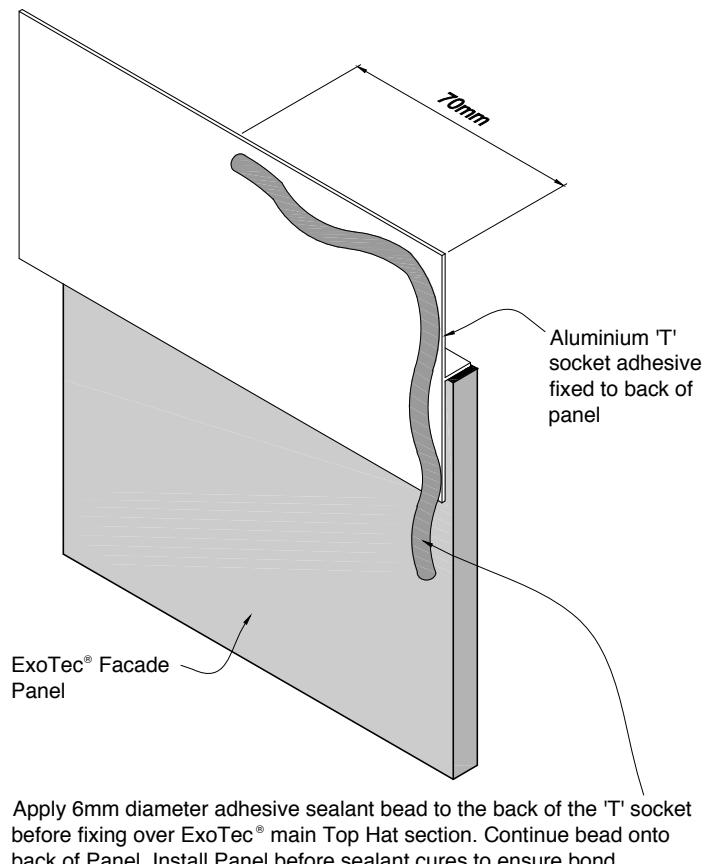

Figure 21: Sealing aluminium 'T' socket to ExoTec Top Hat section

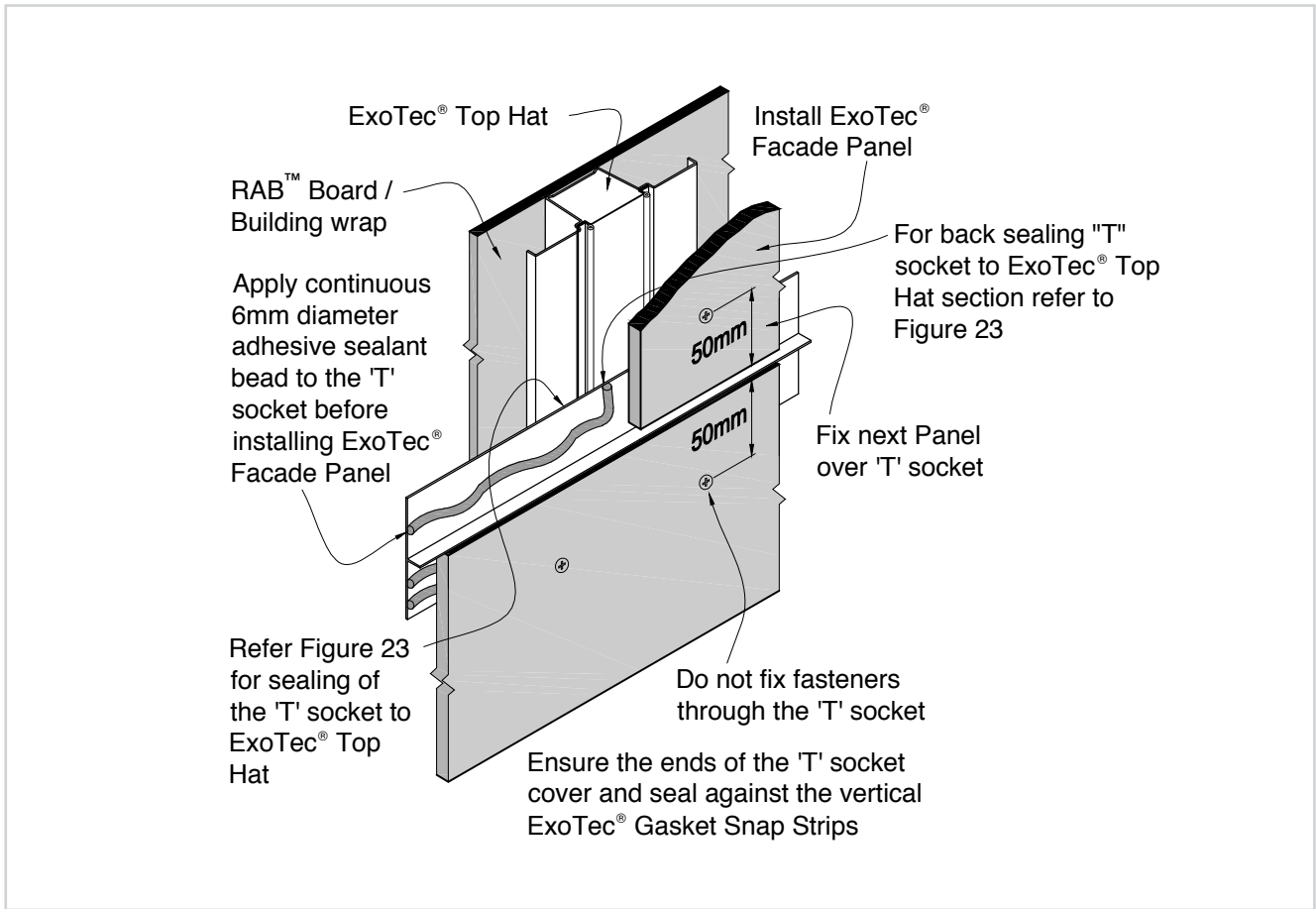

Figure 22: Vertical joint terminating over the horizontal joint

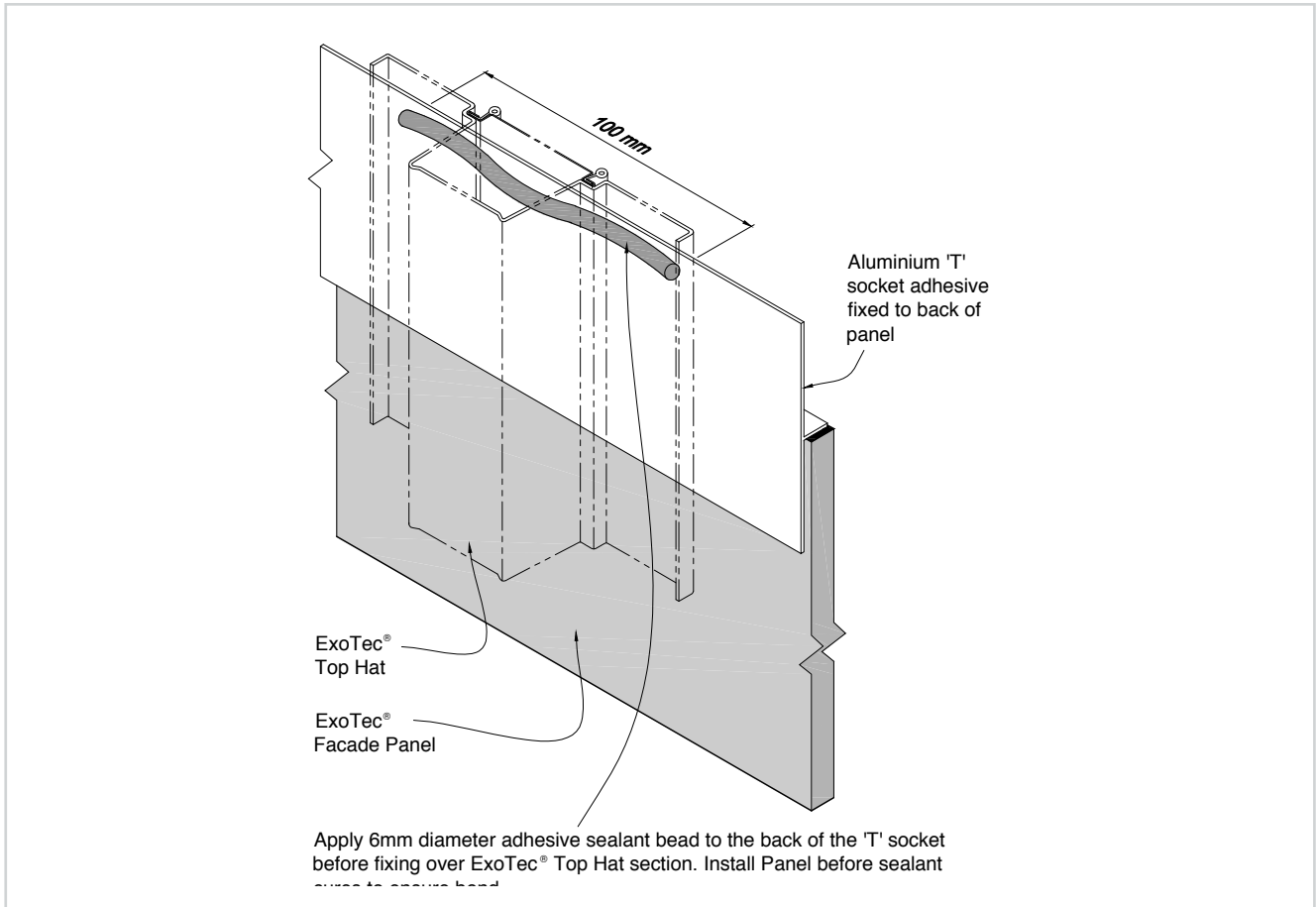

Figure 23: Sealing aluminium 'T' socket to ExoTec® Top Hat

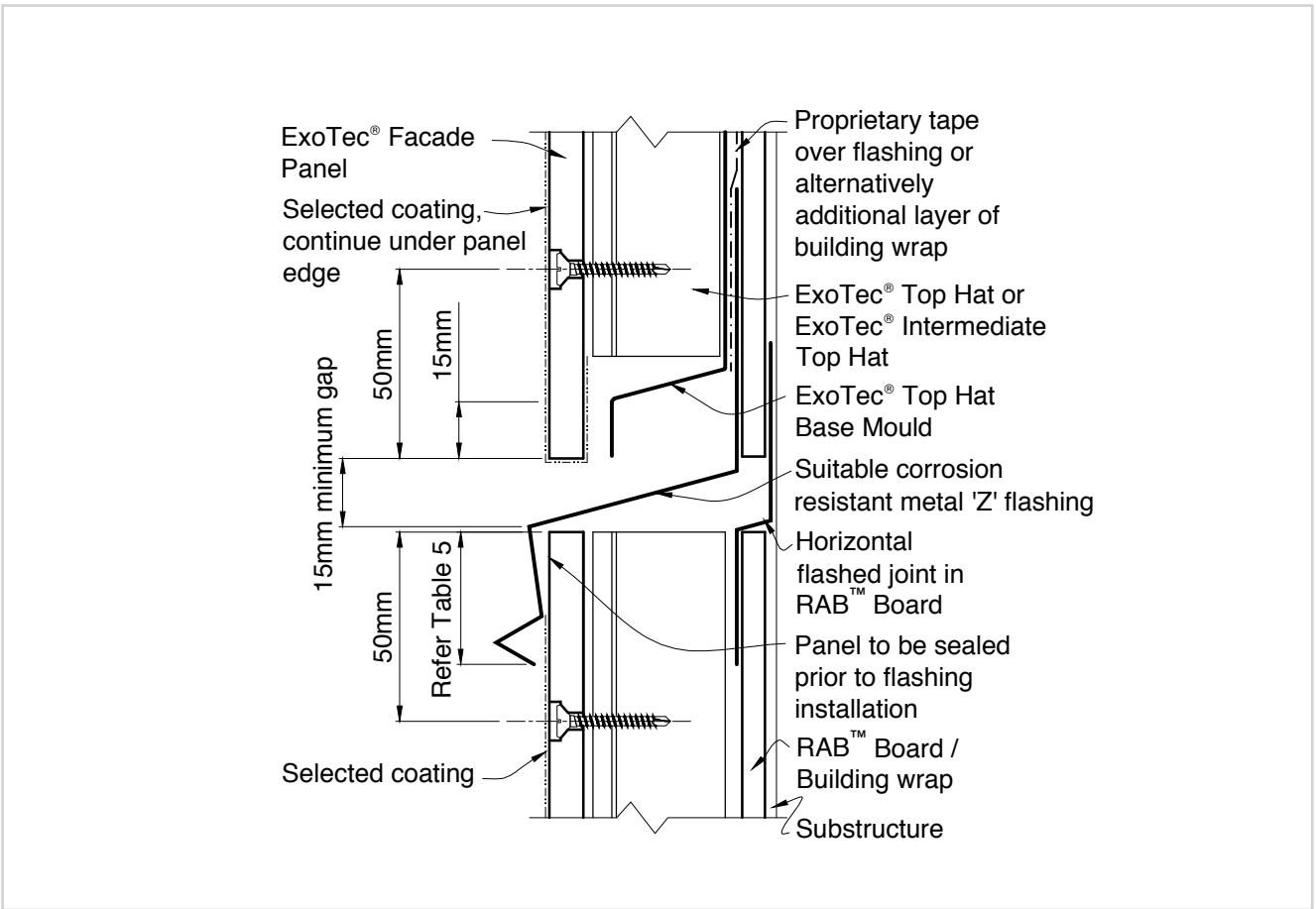

Figure 24: Horizontal structural joint detail

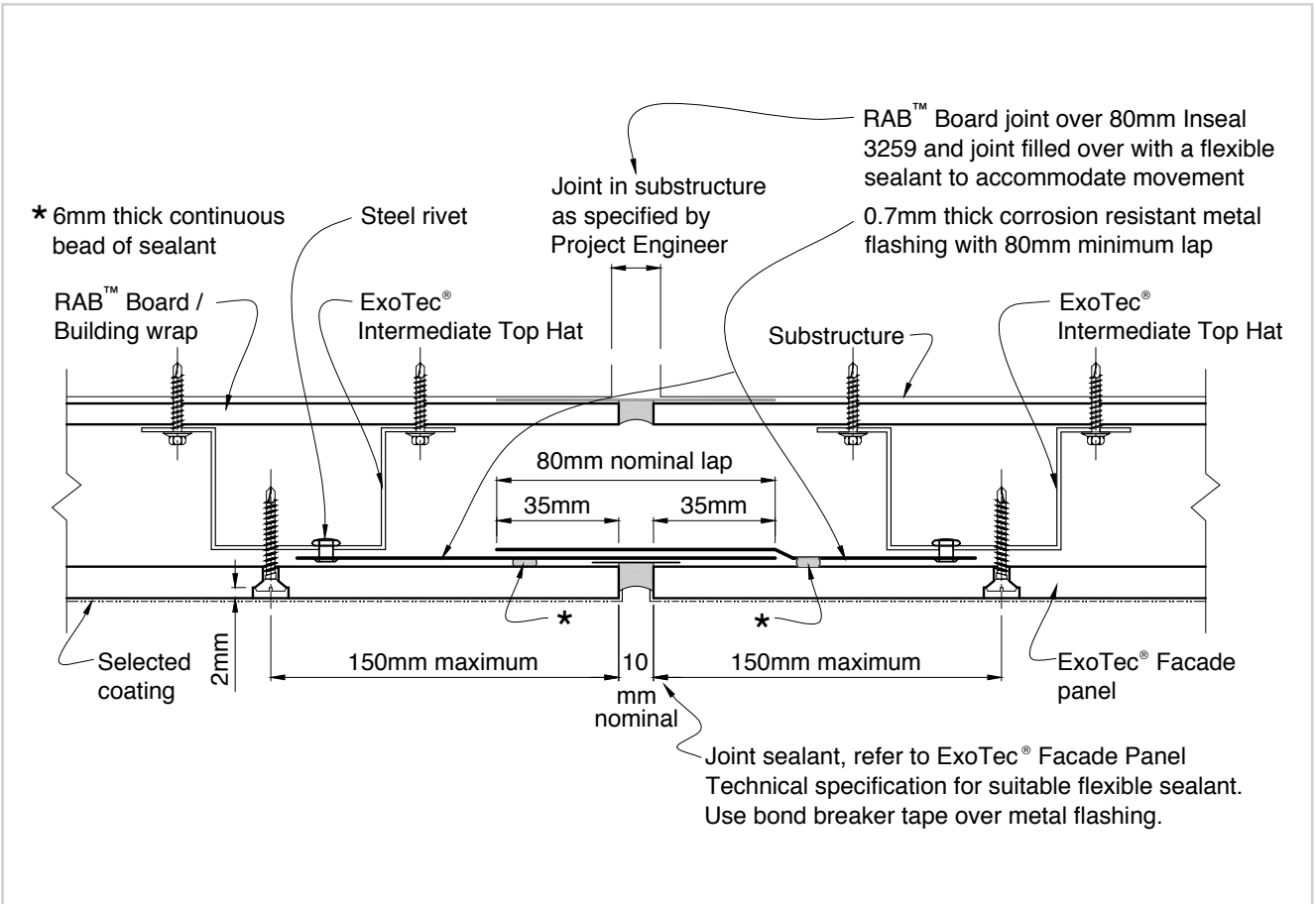

Figure 25: Vertical structural joint detail

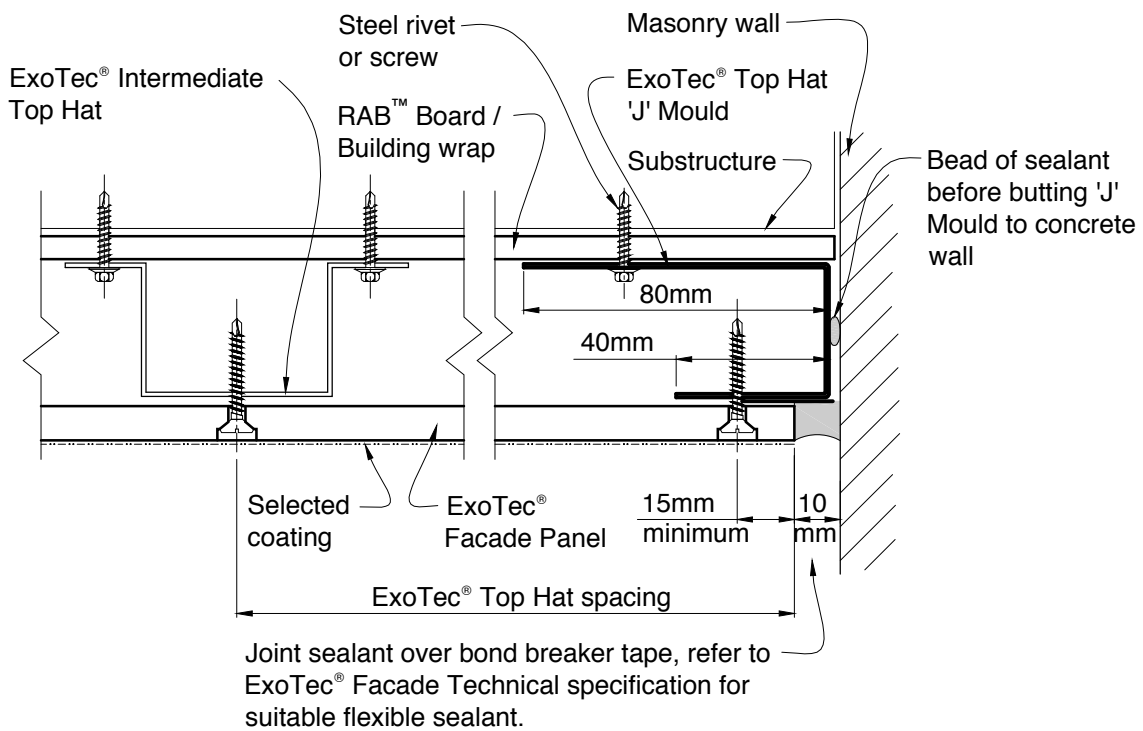

Figure 26: ExoTec Facade Panel and masonry wall abutment

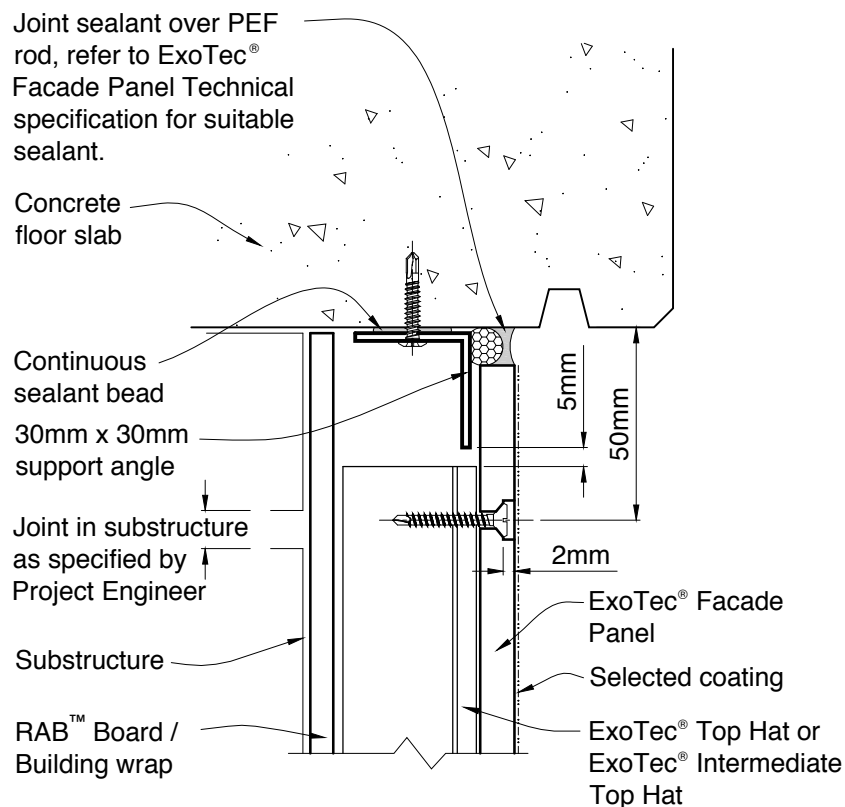

Figure 27: Wall junction under concrete slab detail

Notes

A series of horizontal dotted lines for taking notes.

Notes

A series of horizontal dotted lines for taking notes, spanning the width of the page.

18 Warranty

PRODUCT WARRANTY

August 2010

WARRANTY: James Hardie New Zealand Limited ("James Hardie") warrants for a period of 15 years from the date of purchase that the ExoTec® Facade Panel and RAB™ Board (the "Product"), will be free from defects due to defective factory workmanship or materials and, subject to compliance with the conditions below, will be resistant to cracking, rotting, fire and damage from termite attacks to the extent set out in James Hardie's relevant published literature current at the time of installation. James Hardie warrants for a period of 15 years from the date of purchase that the accessories supplied by James Hardie will be free from defects due to defective factory workmanship or materials.

Nothing in this document shall exclude or modify any legal rights a customer may have under the Consumer Guarantees Act or otherwise which cannot be excluded or modified at law.

CONDITIONS OF WARRANTY:

The warranty is strictly subject to the following conditions:

- (a) James Hardie will not be liable for breach of warranty unless the claimant provides proof of purchase and makes a written claim either within 30 days after the defect would have become reasonably apparent or, if the defect was reasonably apparent prior to installation, then the claim must be made prior to installation.
- (b) This warranty is not transferable.
- (c) The Product must be installed and maintained strictly in accordance with the relevant James Hardie literature current at the time of installation and must be installed in conjunction with the components or products specified in the literature. Further, all other products, including coating and jointing systems, applied to or used in conjunction with the Product must be applied or installed and maintained strictly in accordance with the relevant manufacturer's instructions and good trade practice.
- (d) The project must be designed and constructed in strict compliance with all relevant provisions of the current New Zealand Building Code ("NZBC"), regulations and standards.
- (e) The claimant's sole remedy for breach of warranty is (at James Hardie's option) that James Hardie will either supply replacement product, rectify the affected product or pay for the cost of the replacement or rectification of the affected product.
- (f) James Hardie will not be liable for any losses or damages (whether direct or indirect) including property damage or personal injury, consequential loss, economic loss or loss of profits, arising in contract or negligence or howsoever arising. Without limiting the foregoing James Hardie will not be liable for any claims, damages or defects arising from or in any way attributable to poor workmanship, poor design or detailing, settlement or structural movement and/or movement of materials to which the Product is attached, incorrect design of the structure, acts of God including but not limited to earthquakes, cyclones, floods or other severe weather conditions or unusual climatic conditions, efflorescence or performance of paint/coatings applied to the Product, normal wear and tear, growth of mould, mildew, fungi, bacteria, or any organism on any Product surface or Product (whether on the exposed or unexposed surfaces).
- (g) All warranties, conditions, liabilities and obligations other than those specified in this warranty are excluded to the fullest extent allowed by law.
- (h) If meeting a claim under this warranty involves re-coating of Products, there may be slight colour differences between the original and replacement Products due to the effects of weathering and variations in materials over time.

DISCLAIMER: The recommendations in James Hardie's literature are based on good building practice, but are not an exhaustive statement of all relevant information and are subject to conditions (c), (d), (f) and (g) above. James Hardie has tested the performance of the ExoTec Facade Panel and RAB™ Board when installed in accordance with the ExoTec® Facade Panel and Top Hat Technical Specification, in accordance with the standards and verification methods required by the NZBC and those test results demonstrate the product complies with the performance criteria established by the NZBC. However, as the successful performance of the relevant system depends on numerous factors outside the control of James Hardie (e.g. quality of workmanship and design), James Hardie shall not be liable for the recommendations made in its literature and the performance of the relevant system, including its suitability for any purpose or ability to satisfy the relevant provisions of the NZBC, regulations and standards. It is the responsibility of the building designer to ensure that the details and recommendations provided in the relevant James Hardie installation manual are suitable for the intended project and that specific design is conducted where appropriate.

Copyright August 2010. © James Hardie New Zealand Limited. TM and ® denotes a trademark or registered mark owned by James Hardie Technology Limited.



Ask James Hardie™

Call 0800 808 868

www.jameshardie.co.nz