

Hardie™ Plank Weatherboard 7.5mm

Technical Specification
May 2026 New Zealand





We value your feedback!

To continue with the development of our products and systems, we value your input. Please send any suggestions, including your name, contact details, and relevant sketches to:

Ask James Hardie™
literaturefeedback@jameshardie.co.nz

Make sure your information is up to date

When specifying or installing Hardie™ fibre cement products, ensure that you have the current manual. Additional installation information, warranties and warnings are available at www.jameshardie.co.nz or **Ask James Hardie™** on 0800 808 868.

Contents

| | | | | | |
|----------|--|-----------|-------------------------|--|-----------|
| 1 | Product Information | 4 | 6 | Preparation | 15 |
| 1.1 | Product Sizes and Mass | 4 | 6.1 | HomeRAB™ Pre-Cladding or Flexible Underlay | 15 |
| 1.2 | Manufacturing and Classification | 4 | 6.2 | Rigid Air Barrier and RAB™ Board | 15 |
| 1.3 | Durability | 4 | 6.3 | Flashing | 15 |
| 1.4 | Components and Accessories | 5 | 6.4 | Vent Strip | 15 |
| 2 | Application and Scope | 7 | 6.5 | Cavity Battens | 15 |
| 2.1 | Application | 7 | 6.6 | Intermediate Support | 16 |
| 2.2 | Scope | 7 | 6.7 | External Corners | 16 |
| 2.3 | Details | 7 | 6.8 | Internal Corners | 16 |
| 2.4 | Specific Design | 7 | 6.9 | Junctions and Penetrations | 16 |
| 3 | Design | 8 | 7 | Fixing | 17 |
| 3.1 | Compliance | 8 | 7.1 | General | 17 |
| 3.2 | Responsibility | 8 | 7.2 | Fastener Durability | 17 |
| 3.3 | Clearances | 8 | 7.3 | Nail Sizes and Fixing Method | 17 |
| 3.4 | Moisture Management | 8 | 7.4 | Gun Nailing | 18 |
| 3.5 | Structure | 9 | 8 | Jointing | 20 |
| 3.6 | Wind Loading | 9 | 9 | Finishing | 20 |
| 3.7 | Fire Rated Walls | 9 | 9.1 | Preparation | 20 |
| 3.8 | Energy Efficiency | 9 | 9.2 | Sealants | 20 |
| 4 | Framing | 9 | 9.3 | Painting | 20 |
| 4.1 | General | 9 | 10 | Care and Maintenance | 21 |
| 4.2 | Durability | 10 | 11 | Details | 22 |
| 4.3 | Frame Construction | 10 | Product Warranty | 54 | |
| 4.4 | Tolerances | 10 | | | |
| 5 | Safe Working Practices | 11 | | | |
| 5.1 | Storage and delivery | 14 | | | |
| 5.2 | Tips for safe and easy handling of Hardie™ Plank Weatherboard 7.5mm | 14 | | | |

1 Product Information

1.1 Product Sizes and Mass

Hardie™ Plank Weatherboard 7.5mm is available in two different profiles with sizes and weights given in Table 1. Hardie™ Plank Weatherboard 7.5mm are classified as a light weight wall cladding (not exceeding 30kg/m²) in accordance with NZS 3604.

Table 1

| Product information | | | | | | | | | |
|---------------------|--------|-------------|------------|----------------|----------------------|----------------------------|-----------------------------------|--|-----------------------------------|
| Product | Code | Length (mm) | Width (mm) | Thickness (mm) | Coverage information | | | | Pallet weight kg (120 units/pack) |
| | | | | | Effective cover | No. of planks/metre height | Mass kg/lineal m (approx. at EMC) | Mass kg/m ² approx. at EMC) | |
| Smooth | 401663 | 4200 | 180 | 7.5 | 150 | 6.7 | 2.4 | 16.0 | 1170 |
| | 400266 | 4200 | 300 | 7.5 | 270 | 3.6 | 3.6 | 12.9 | 1900 |
| Woodgrain | 403081 | 4200 | 300 | 7.5 | 270 | 3.6 | 3.6 | 12.9 | 1900 |

Note: All dimensions provided are based on nominal only and subject to manufacturing tolerances.

*The effective thickness of finished Hardie™ Plank Weatherboard 7.5mm on the wall at the lap is approx 17-19mm.

1.2 Manufacturing and Classification

James Hardie is an ISO 9001 certified manufacturer. Hardie™ Plank Weatherboard 7.5mm are manufactured to meet the requirements of AS/NZS 2908.2: 2000 'Cellulose-Cement Products', Hardie™ Plank Weatherboard 7.5mm have a classification of Type A Category 3 in accordance with this standard. The basic composition is Portland cement, ground sand, cellulose fibre, water and proprietary additives.

The weatherboards are supplied un-primed. The ends are guillotine cut and top and bottom edges are square water-jet trimmed.

Hardie™ Plank Weatherboard 7.5mm is identified by the printing of the name at regular intervals on the back face.

1.3 Durability

Hardie™ Plank Weatherboard 7.5mm, when installed and maintained as per the technical specification, will meet the durability requirements for claddings as required in the NZBC Approved Document B2 'Durability'.

1.3.1 Resistance to Moisture/Rotting

Hardie™ Plank Weatherboard 7.5mm demonstrates resistance to permanent moisture induced deterioration (rotting) and has passed the following tests in accordance with AS/NZS 2908.2

- Heat Rain (Clause 6.5)
- Water Permeability (Clause 8.2.2)
- Warm Water (Clause 8.2.4)
- Soak Dry (Clause 8.2.5).

1.3.2 Fire Performance

Hardie™ Plank Weatherboard 7.5mm have been tested/assessed to AS/NZS 3837 and are suitable for use where non-combustible materials are specified.

1.3.3 Alpine Regions

In regions subject to freeze/thaw conditions, Hardie™ Plank Weatherboard 7.5mm must not be in direct contact with snow or ice build up for extended periods, e.g. external walls in alpine regions must be protected where snow drifts over winter is expected.







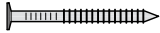

The Hardie™ Plank Weatherboard 7.5mm has been tested in accordance with AS/NZS 2908.2 Clause 8.2.3.

1.4 Components and Accessories

Table 2

| Accessories/tools supplied by James Hardie | | | | |
|---|---|-------------------------------------|--------------------------------------|--|
| | Accessory and material number | Size (mm) | Material/appearance | |
|  | Hardie™ Plank 7.5mm External Corner Soaker 303930 303932 | 310 180 | Etch Primed Aluminium Self colour | |
|  | Hardie™ Plank 7.5mm Concealed Back Soaker 303933 303936 | 310 180 | Etch Primed Aluminium Self colour | |
|  | Hardie™ Plank 7.5mm External Box Corner 300380 300378 | 3000 2700 | Etch Primed Aluminium | |
|  | Hardie™ Plank 7.5mm External Corner 135° 300375 | 2700 | Etch Primed Aluminium | |
|  | Hardie™ Plank 7.5mm Internal Corner 135° 300383 | 2700 long | Etch Primed Aluminium | |
|  | Corner Underflashing - 50 x 50 303745 | 3000 long | uPVC | |
|  | Vent Strip 302490 | 3000 long | PVC White | |
|  | Hardie™ Plank 7.5mm Internal 'W' Corner 306220 306262 306180 | 2750 long 3000 long 4000 long | Etch Primed Aluminium | |
|  | Hardie™ Flex nail - 5kg 304253 | 75 x 3.15mm | 316 Stainless Steel | |
|  | Hardie™ Flex nail - 5kg 304251 | 75 x 3.15mm | Hot Dip Galvanised | |
|  | Hardie™ Blade Saw Blade Diamond tip fibre cement circular saw blade. Spacers not included. 300660 | 184mm | Diamond Tipped | |
|  | Hardie™ Blade Saw Blade Diamond tip fibre cement circular saw blade. Spacers not included. 303375 | 254mm | Diamond Tipped | |
|  | Hardie™ Knife Scoring tool for easy cutting. 305926 | | | |

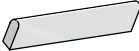
Table 3

| Accessories/tools not supplied by James Hardie | | | |
|--|--|---|---|
| James Hardie recommends the following products for use in conjunction with its Hardie™ Plank Weatherboard 7.5mm. James Hardie does not supply these products. Please contact component manufacturer for information on their warranties and further information on their products. | | | |
| | Accessory and material number | Size (mm) | Material/ appearance |
|  | Hardie™ Flex nail | 40 x 2.8mm and 50 x 2.8mm | 316 Stainless Steel |
|  | Hardie™ Flex nail | 40 x 2.8mm and 50 x 2.8mm | Hot Dip Galvanised |
|  | Flexible sealant ie: Sikaflex® AT Facade | Tube | Cured rubberised compound |
|  | PEF Rod Sika® Boom or similar | Polyethylene foam | Semi rigid foam |
|  | Flashing Tape Tyvek®, Protecto® Wrap or similar | Proprietary tape to adhere to flexible underlay | |
|  | Inter storey flashing to Table C.1.1.1A 'E2/AS1' | | Flashing fabricator |
|  | Timber Scriber | As required | H3.1 Treated Timber. Timber merchant or cut on site |
|  | Solid timber cavity Batten | Nominal 20 x 45mm | H3.1 Treated Timber |
|  | Cant Strip | To suit | H3.1 treated timber or uPVC |

2 Application and Scope

2.1 Application

Hardie™ Plank Weatherboard 7.5mm is made of fibre cement. It is categorised as a lightweight cladding product as per NZS 3604.

Hardie™ Plank Weatherboard 7.5mm

Hardie™ Plank Weatherboard 7.5mm is available in two profiles. The woodgrain finish in a 300mm width and the smooth finish in 180mm and 300mm widths.

Specifier

If you are a specifier or other responsible party for a project, ensure that the information in this document is appropriate for the application you are planning and that you undertake specific design and detailing for areas which fall outside the scope of these specifications.

Installer

If you are an installer ensure that you follow the design, moisture management principles, and associated details and material selection provided by the designer. All the details provided in this document must be read in conjunction with the specifier's specification.

Make sure your information is up to date

When specifying or installing Hardie™ fibre cement products, ensure you have the current manual. If you're not sure you do, or you need more information, visit www.jameshardie.co.nz or Ask James Hardie™ on 0800 808 868.

2.2 Scope

This specification covers the use of Hardie™ Plank Weatherboard 7.5mm for buildings that fall within the scope of the NZS 3604 and the NZBC Acceptable Solution 'E2/AS1', Paragraph 1.1.1.1. The specification covers the use of Hardie™ Plank Weatherboard 7.5mm in both direct fixed and cavity construction methods. Please refer to 'E2/AS1' for further information regarding the selection of construction method for claddings.

2.3 Details

Various Hardie™ Plank Weatherboard 7.5mm details are provided in the Details section of this document. This specification and details in CAD file are also available to download from our website at www.jameshardie.co.nz.

2.4 Specific Design

For use of Hardie™ Plank Weatherboard 7.5mm outside the scope of this document, the architect, designer or engineer must undertake specific design. For advice on designs outside the scope of this specification, Ask James Hardie on 0800 808 868.

3 Design

3.1 Compliance

Hardie™ Plank Weatherboard 7.5mm fibre cement material complies with the requirements of paragraph 4.2.1.2 of Building Product Specification of the NZBC.

The installation details published in this technical specification are aligned with Sub-Section 9.5.3 of E2/AS1 of the NZBC. Information contained in this document regarding the installation of Hardie™ Plank Weatherboard 7.5mm are aligned with 'E2/AS1' of the New Zealand Building Code (NZBC).

3.2 Responsibility

The specifier or other party responsible for the project must ensure that the information and details in this specification are appropriate for the intended application and that additional detailing is performed for specific design or any areas that fall outside the scope of this technical specification. For applications outside the scope of this literature and details which are not provided herein, the architect, designer or engineer must undertake specific design and it should be ensured that the intent of their design meets the requirements of the NZBC.

All dimensions shown are in millimetres unless noted otherwise. All New Zealand Standards referenced in this manual are current edition and must be complied with.

James Hardie conduct stringent quality checks to ensure that any product manufactured falls within our quality spectrum. It is the responsibility of the builder to ensure that the product meets aesthetic requirements before installation. James Hardie will not be responsible for rectifying obvious aesthetic surface variations following installation.

3.3 Clearances

The clearance between the bottom edge of the cladding and paved/unpaved ground must comply with Subsection 9.1.2 of E2/AS1. The finished floor level must also comply with these requirements. These clearances must be maintained throughout the life of the building.

Hardie™ Plank Weatherboard 7.5mm must overhang the bottom plate on a concrete slab by a minimum of 50mm as per Table 9.1.2.1, and for timber sub floor framing as per Paragraph 9.1.2.8 of the NZBC Acceptable Solution E2/AS1.

Hardie™ Plank Weatherboard 7.5mm must have a minimum clearance of 100mm from paved ground and 175mm from unpaved ground.

On roofs and decks the minimum clearance must be 50mm.

3.4 Moisture Management

It is the responsibility of the specifier to identify moisture related risks associated with any particular building design.

Wall construction design must effectively manage moisture, considering both the interior and exterior environments of the building, particularly in buildings that have a higher risk of wind driven rain penetration or that are artificially heated or cooled.

Walls must include those provisions as required by the NZBC Acceptable Solution 'E2/AS1' 'External Moisture'. In addition all wall openings, penetrations, junctions, connections, window sills, heads and jambs must incorporate appropriate flashing for waterproofing. The other materials, components and installation methods used to manage moisture in the walls, must comply with the requirements of relevant standards and the NZBC. For further information in relation to designing for weathertightness, refer to the Building Research Association of New Zealand (BRANZ)

and the Ministry of Business, Innovation and Employment (MBIE) updates on the following websites, respectively www.branz.co.nz and www.building.govt.nz.

3.5 Structure

Timber framed buildings must either be in accordance with the NZS 3604 (Timber-framed buildings) or designed as per specific engineering design (SED) up to Extra High (EH) wind zone and 10m height max.

A 90 x 45mm minimum framing size is required.

The information published in this specification has been assessed for a timber structural grade SG8 at minimum. Refer to the NZS 3604 for further information on structural grades and their application.

3.6 Wind Loading

Hardie™ Plank Weatherboard 7.5mm is suitable for use in all wind zones in New Zealand up to and including EH as defined in NZS 3604.

A specific design is required for all situations where a building falls in a specific engineering design (SED) wind zone.

3.7 Fire Rated Walls

Walls clad with Hardie™ Plank Weatherboard 7.5mm using a direct fix or cavity construction method can achieve fire ratings of up to 60/60/60 to comply with C/AS1 of the NZBC, when constructed in accordance with this literature, including the fire rated system requirements as specified in the Fire and Acoustic Design Manual by James Hardie. Refer to this design manual for further information about fire rated systems.

3.8 Energy Efficiency

External walls constructed as per this technical specification, using Hardie™ Plank Weatherboard 7.5mm cladding must use suitable bulk insulation to meet the minimum thermal insulation requirements as per Clause H1/AS1 'Energy Efficiency' of the NZBC.

4 Framing

4.1 General

This Hardie™ Plank Weatherboard 7.5mm technical specification is only suitable for timber-framed buildings. Other framing materials are outside the scope of this specification.

4.2 Durability

To comply with the NZBC requirements the external framing must be treated to a minimum H1.2 treatment. Refer to the NZBC Acceptable Solution B2/AS1 'Durability' for further information about the durability requirements.

For timber treatment information refer to NZS 3602 (Timber and Wood-Based Products for use in Buildings) and NZS 3640 (Chemical Preservation of Round and Sawn Timber) for minimum timber treatment selection and treatment requirements.

Also refer to framing manufacturer's literature for further guidance on timber selection. Framing must be protected from moisture at sites in accordance with the recommendations of framing manufacturer's.

Note: Refer to NZS 3602 for information about the allowable moisture contents in timber.

4.3 Frame Construction

All timber framing sizes and set-out must comply with NZS 3604 and stud, nogs/dwangs centres as required by this specification.

Use of timber framing must be in accordance with framing manufacturer's specifications.

In case of gable end trusses sitting on top plate of external wall frame, the frame size must be in accordance with truss design and specification supplied by the frame and truss manufacturer/supplier supported by independent design producer statement.

4.3.1 Direct Fix Construction Method

Buildings with a risk score of 1-6 assessed as per Part 3 of E2/AS1 Table 3.1.3.1, Hardie™ Plank Weatherboard 7.5mm can be direct fixed.

The following framing must be provided for direct fixed construction method:

- Studs provided at 600mm centres maximum
- Nogs provided at 1200mm centres maximum
- Double studs will be required at internal corners for fixing weatherboards without drilling the weatherboard ends

4.3.2 Cavity Construction Method

Buildings with a risk score of 7-20 assessed as per Part 3 of E2/AS1 Table 3.1.3.1 requires Hardie™ Plank Weatherboard 7.5mm to be installed on a cavity.

The following framing must be provided for cavity construction method:

- When studs are at 600mm centres the nogs must be provided at 800mm centres maximum
- When studs are at 400mm centres the nogs may be provided at 1200mm centres maximum
- Double studs are required at internal corners
- Extra blocking may be required at external corners

4.4 Tolerances

In order to achieve an acceptable wall finish, it is imperative that framing is straight and true. Framing tolerances must comply with the requirements of the NZS 3604 and the manufacturer's specifications. All framing must be made flush.

The visual aspects of the finished cladding can differ between two different sites or the builders installing the product. It is recommended that you also refer to a building guidance document published by MBIE to understand an acceptable level of tolerances allowed in building materials and workmanship. The 'Guide to tolerances, materials and workmanship in new residential construction 2015' can be found at www.building.govt.nz.

5 Safe Working Practices

WARNING - DO NOT BREATHE DUST AND CUT ONLY IN WELL VENTILATED AREA

Hardie™ fibre cement products contain sand, a source of respirable crystalline silica

May cause cancer if dust from product is inhaled. Causes damage to lungs and respiratory system through prolonged or repeated inhalation of dust from product.

Intact fibre cement products are not expected to result in any adverse toxic effects. The hazard associated with fibre cement arises from the respirable crystalline silica present in dust generated by activities such as cutting, rebating, drilling, routing, sawing, crushing, or otherwise abrading fibre cement, and when cleaning up, disposing of or moving dust.

When doing any of these activities in a manner that generates dust, follow James Hardie's instructions and best practices to reduce or limit the release of dust.

If using a dust mask or respirator, use an AS/NZS 1716 P1 filter and refer to Australian/New Zealand Standard 1715:2009 Selection, Use and Maintenance of Respiratory Protective Equipment for more extensive guidance and more options for selecting respirators for workplaces. For further information, refer to our installation instructions and Safety Data Sheets available at www.jameshardie.co.nz.

FAILURE TO ADHERE TO OUR WARNINGS, SAFETY DATA SHEETS, AND INSTALLATION INSTRUCTIONS MAY LEAD TO SERIOUS PERSONAL INJURY OR DEATH.

Crystalline Silica is

- Commonly known as sand or quartz
- Found in many building products e.g. concrete, bricks, grout, wallboard, ceramic tiles, and all fibre cement materials

Why is Crystalline Silica a health hazard?

- Silica can be breathed deep into the lungs when present in the air as a very fine (respirable) dust
- Exposure to silica dust without taking the appropriate safety measures to minimise the amount being breathed in, can lead to a potentially fatal lung disease – silicosis – and has also been linked with other diseases including cancer. Some studies suggest that smoking may increase these risks
- The most hazardous dust is the dust you cannot see!

When is Crystalline Silica a health hazard?

- It's dangerous to health if safety protocols to control dust are not followed when cutting, drilling or rebating a product containing crystalline silica and when cleaning up
- Products containing silica are harmless if intact (e.g. an un-cut sheet of wall board)

Avoid breathing in crystalline silica dust

Safe working practices

- ✗ NEVER use a power saw indoors or in a poorly ventilated area
- ✗ NEVER dry sweep
- ✓ ALWAYS use M Class or higher vacuum or damp down dust before sweeping up
- ✗ NEVER use grinders
- ✓ ALWAYS use a dust reducing circular saw equipped with a sawblade specifically designed to minimise dust creation when cutting fibre cement – preferably a sawblade that carries the Hardie™ Blade name or one with at least equivalent performance – connected to an M Class or higher vacuum
- ✓ Before cutting warn others in the area to avoid dust
- ✓ ALWAYS follow tool manufacturers' safety recommendations
- ✓ ALWAYS expose only the minimum required depth of blade for the thickness of fibre cement to be cut
- ✓ ALWAYS wear a properly-fitted, approved dust mask or respirator P1 or higher in accordance with applicable government regulations and manufacturer instructions
- ✓ Consider rotating personnel across cutting tasks to further limit respirable silica exposures.

Use one of the following methods for cutting Hardie™ Plank Weatherboard 7.5mm:

Best

- Hardie™ Knife
- Hand guillotine
- Fibreshear

Better

Dust reducing circular saw equipped with Hardie™ Blade Saw Blade and connected to a M Class or higher vacuum.

When cutting outdoors

- ✓ Make sure you work in a well ventilated area
- ✓ Position cutting station so wind will blow dust away from yourself and others in the working area
- ✓ Rotate employees across cutting task over duration of shift
- ✓ Cut products with a Hardie™ Blade Saw Blade (or equivalent) and a dust reducing circular saw connected to a M Class or higher vacuum
- ✓ When sawing, sanding, rebating, drilling or machining fibre cement products, always:
 - Wear your P1 or higher (correctly fitted in accordance with manufacturers' instructions), ask others to do the same.
 - Keep persons on site at least 2 metres and as far as practicable away from the cutting station while the saw is in operation
 - If you are not clean shaven, then use a powered air respirator with a loose fitting head top
 - Wear safety glasses
 - Wear hearing protection
- ✓ Make sure you clean up BUT never dry sweep. Always hose down with water/wet wipe or use an M Class or higher vacuum

When cutting indoors

- ✗ Never cut using a circular saw indoors
- ✓ Position cutting station in a well ventilated area
- ✓ Cut ONLY using a Hardie™ Knife, hand guillotine or fibreshears (manual, electric or pneumatic)
- ✓ Make sure you clean up BUT never dry sweep. Always hose down with water/wet wipe or use an M Class or higher vacuum

If concern still exists about exposure levels or you do not comply with the above practices, you should always consult a qualified industrial hygienist or contact James Hardie for further information.

Working instructions

Hardie™ Blade Saw Blade

The Hardie™ Blade Saw Blade used with a dust-reducing saw is ideal for fast, clean cutting of Hardie™ fibre cement products. A dust-reducing saw uses a dust collector connected to a M Class or higher vacuum. When sawing, clamp a straight edge to the sheet as a guide and run the saw base plate along the straight edge when making the cut.

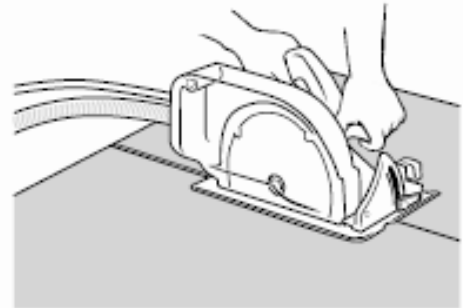

Hole forming

For smooth clean cut circular holes:

- Mark the centre of the hole on the sheet
- Pre-drill a 'pilot' hole
- Using the pilot hole as a guide, cut the hole to the appropriate diameter with a hole saw fitted to a heavy duty electric drill



For irregular holes:

- Small rectangular or circular holes can be cut by drilling a series of small holes around the perimeter of the hole then tapping out the waste piece from the sheet face
- Tap carefully to avoid damage to sheets, ensuring that the sheet edges are properly supported

5.1 Storage and delivery

Keeping products and people safe

Off loading

- ✓ Hardie™ fibre cement products should be off-loaded carefully by hand or by forklift
- ✓ Hardie™ fibre cement products should not be rolled or dumped off a truck during the delivery to the jobsite

Storage

Hardie™ fibre cement products should be stored:

- ✓ In their original packaging
- ✓ Under cover where possible or otherwise protected with a waterproof covering to keep products dry
- ✓ Off the ground – either on a pallet or adequately supported on timber or other spacers
- ✓ Flat so as to minimise bending

Hardie™ fibre cement products must not be stored:

- ✗ Directly on the ground
- ✗ In the open air exposed to the elements

James Hardie is not responsible for damage due to improper storage and handling.

5.2 Tips for safe and easy handling of Hardie™ Plank Weatherboard 7.5mm

- ✓ Carry with two people
- ✓ Hold near each end and on edge
- ✓ Exercise care when handling sheet products to avoid damaging the edges/corners

6 Preparation

6.1 HomeRAB™ Pre-Cladding or Flexible Underlay

HomeRAB™ Pre-Cladding or flexible underlay must be provided as per the requirements of the NZBC Acceptable Solution 'E2/AS1' 'External Moisture' and NZS 3604.

The flexible underlays must comply with Table C.2.1.1 of 'E2/AS1'. The flexible underlays must be fixed in accordance with 'E2/AS1', NZS 3604 and the underlay manufacturer's recommendations.

Walls which are not lined on the inside face (e.g. garage walls or gable ends) must include a rigid sheathing or an air barrier behind the cladding which complies with the requirements of the NZBC 'Acceptable Solution' 'E2/AS1'. HomeRAB™ Pre-Cladding is suitable for use in these applications. It must be installed in accordance with HomeRAB™ Pre-Cladding and RAB™ Board Installation Manual.

6.2 Rigid Air Barrier and RAB™ Board

In EH wind zone or for specific design wind zone, a rigid air barrier such as RAB™ Board, must be used instead of flexible underlay. To achieve the temporary weathertightness using pre-cladding products from James Hardie, windows and doors must be installed with required flashing tapes and seals etc. Refer to the HomeRAB™ Pre-Cladding and RAB™ Board Installation Manual for information regarding its installation and requirements to achieve temporary weathertightness. For other rigid air barriers please refer to that manufacturers technical specification.

6.3 Flashing

All wall openings, penetrations, intersections, connections, window sills, heads and jambs must be flashed prior to weatherboard installation. Please refer to moisture management requirements in Clause 2.5. The flexible underlays must be appropriately incorporated with penetration and junction flashings. Materials must be lapped in such a way that water tracks down to the exterior on the face of flexible underlay.

The selected flashing materials must comply with the durability requirements of Table C.1.1.1A of Acceptable Solution 'E2/AS1'.

6.4 Vent Strip

The Hardie™ uPVC cavity vent strip has a ventilation area of 1000mm²/m length and must be installed at the bottom of all walls constructed using the drained and ventilated cavity construction method. It is important that the openings in the vent strip are kept clear and unobstructed to allow free drainage and ventilation of cavities. Mitre the Hardie™ uPVC cavity vent strip at corners.

6.5 Cavity Battens

The battens provide airspace between the frame and cladding and are considered a 'packer' only in this specification.

The timber battens must be minimum H3.1 treated in accordance with NZS 3640 (Chemical preservation of round and sawn timber) to comply with the durability requirements of B2/AS1.

Cavity battens must comply with 'E2/AS1' and

- Be minimum 18mm thick and 45mm wide
- Be fixed by the cladding fixings to the main framing through the flexible underlay

- Until claddings are fixed the battens need only to be tacked to framing. Batten fixing is required temporarily to keep them straight on the wall during construction.

The cavity battens are installed as described below:

- Fix cavity battens to studs
- Battens must be fixed with 40 x 2.8mm galvanised nails at 800mm centres maximum

6.6 Intermediate Support

Where studs are at 600mm centres an intermediate means of restraining the flexible underlay and insulation from bulging into the cavity shall be installed. An acceptable solution as per Paragraph 9.1.7.10 of E2/AS1 of the NZBC is using one of the following options as per E2/AS1:

- Intermediate cavity batten between the studs
- 75mm galvanised mesh
- Polypropylene tape at 300mm centres fixed horizontally and drawn taut

No intermediate supports are required where

- Studs are at 400mm centres or
- Rigid air barriers instead of flexible underlays are used

6.7 External Corners

Hardie™ Plank Weatherboard 7.5mm shall be finished at external corners using Hardie™ Plank 7.5mm aluminium corner mould, corner soakers or box corner. Refer to Figures 5, 6, 7, 19, 20 and 21.

6.8 Internal Corners

Hardie™ Plank Weatherboard 7.5mm shall be finished at internal corners using Hardie™ Plank 7.5mm aluminium 'W' moulds. Refer to Figures 8, 9, 22 and 23.

6.9 Junctions and Penetrations

Refer to Clause 2.5 of this specification for moisture management requirements. All windows and doors must be detailed as per the requirements of this specification. James Hardie has developed the window details for Hardie™ Plank Weatherboard 7.5mm which meet the requirements of E2 'External Moisture' approved document of the NZBC. Refer to Figures 11 to 13 and Figures 25 to 33.

7 Fixing

7.1 General

The horizontal lap of Hardie™ Plank Weatherboard 7.5mm must be 30mm minimum. Hardie™ Plank Weatherboard 7.5mm must be kept dry and under cover whilst in storage prior to and during fixing.

Ends which are exposed such as internal corners or where sealant is applied to the boards must be primed prior to installation. Dust and loose material must be removed before priming.

An H3.1 treated timber cant strip must be provided to support the bottom board on the wall. Refer to Figures 3 and 17.

7.2 Fastener Durability

Fasteners must meet the durability requirements of the NZBC. NZS 3604 specifies requirements for fixing material to be used in relation to the exposure conditions and are summarised below in Table 4.

Table 4

| Exposure conditions and nail selection prescribed by NZS 3604 | | |
|---|-------------|--|
| Zone | Application | |
| D (sea spray) and geothermal hot spots | General | Stainless steel 304/316 |
| | Fire | |
| C* and B | General | Hot dip galvanised Must comply with AS/NZS 4680 |
| | Fire | |

* Zone C areas where local knowledge dictates that increased durability is required, appropriate selection shall be made Microclimate conditions as detailed in NZS 3604, Paragraph 4.2.4 require SED.

Also refer to the NZBC Acceptable Solution E2/AS1 Table C.1.1.1A and C.1.1.1B for information regarding the selection of suitable fixing materials and their compatibility with other materials.

7.3 Nail Sizes and Fixing Method

Hardie™ Plank Weatherboard 7.5mm must be fixed to studs with the types of nails specified in Table 5, in accordance with the following requirements:

- All nails must be driven flush with the board surface
- When fixing weatherboard at the ends, nail must be driven at a minimum distance of 20mm from the end
- For nails driven 50mm or closer from the end edges of Hardie™ Plank Weatherboard 7.5mm, holes must be pre-drilled using a 3mm titanium drill bit

Table 5

| Nail requirements for Hardie™ Plank Weatherboard 7.5mm | |
|---|-------------------------------------|
| DIRECT FIXED TO FRAME | |
| Face nailing | |
| 50 x 2.8mm Hardie™ Flex nails | Finish flush with the board surface |
| CAVITY CONSTRUCTION | |
| Face nailing over flexible underlay | |
| 75 x 3.15mm Hardie™ Flex nails | Finish flush with the board surface |
| CAVITY CONSTRUCTION | |
| Face nailing over RAB Board or HomeRAB Pre-Cladding | |
| 75 x 3.15mm Hardie™ Flex nails | Finish flush with the board surface |

7.4 Gun Nailing

Hardie™ Plank Weatherboard 7.5mm can either be gun nailed or hand nailed. Nails must be finished flush with board surface.

Round head nails must be used and the size of these nails must comply with the requirements of Table 5.

Nails must be fired at a minimum distance of 50mm from the ends of boards.

Note: Do not use 'D' head nails.

Nail depth



Roundhead Nail
(Plan view)

Nail head flush
with face of
weatherboard
under the lap

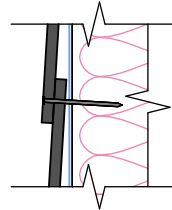
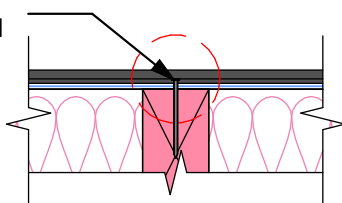

Nail head firm
with face of
weatherboard
under the lap

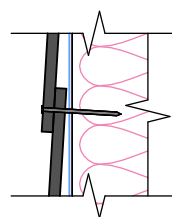
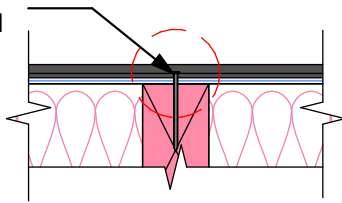

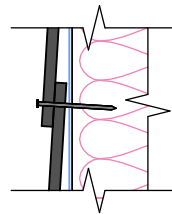
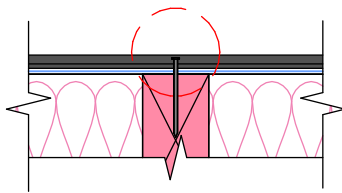

(CORRECT)

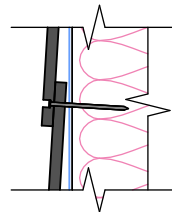
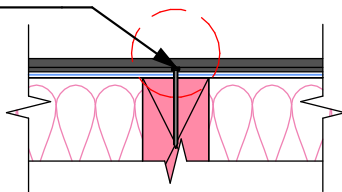

(INCORRECT)

Punched



(INCORRECT)

8 Jointing

The ends of Hardie™ Plank Weatherboard 7.5mm are jointed off-stud using a back soaker. The joints may be located centrally between studs but no closer than 150mm from the studs. The joints must be staggered by 600mm minimum. The Hardie™ Plank Weatherboard 7.5mm must span over 2 studs. Flexible silicone sealant must be used with back soakers for jointing. Refer to Figures 4 and 18.

9 Finishing

Protective coating of Hardie™ Plank Weatherboard 7.5mm is required in order to meet the durability requirements of the New Zealand Building Code.

9.1 Preparation

Remove any surface dirt, grime or other contaminants and ensure the Hardie™ Plank Weatherboard 7.5mm are dry before painting.

9.2 Sealants

All sealants must demonstrate the ability to meet the relevant requirements of the NZBC. Their application and usage must be in accordance with manufacturer's instructions. Sealants, if coated, must be compatible with the paint system.

9.3 Painting

All Hardie™ Plank Weatherboard 7.5mm are un-primed.

Hardie™ Plank Weatherboard 7.5mm must be painted within 90 days of installation. It is recommended to prime the Hardie™ Plank Weatherboard 7.5mm before the application of a coating system. All exposed faces, including the top edges under the sills and bottom edges of Hardie™ Plank Weatherboard 7.5mm and accessories must be finished with a quality exterior paint system complying with any of parts 7, 8, 9, and 10 of AS 3730.

Hardie™ Plank Weatherboard 7.5mm can be painted dark colours when installed with aluminium mouldings only.

When using uPVC corner moulds or flashings, the light reflective value of the colour used must be more than 40% as required under section 4.2.2 of 'E2/AS1'.

For best aesthetic results a low sheen paint is recommended. Some environments require special coatings. Paint selection and specifications is dependant on the paint system chosen. Refer to the paint manufacturer.

10 Care and Maintenance

The extent and nature of maintenance will depend on the geographical location and exposure of the building. Refer to Section 2.2 of E2/AS1 and Section 2.2 of B2/AS1 for essential maintenance requirements for claddings to achieve the required durability of materials and components etc. As a guide, it is recommended that basic normal maintenance tasks for Hardie™ Plank Weatherboard 7.5mm cladding shall include but not be limited to:

- Washing down exterior surfaces every 6-12 months using low pressure water and a brush, and every 3-4 months in extreme coastal conditions or sea spray zones. Do not use a water blaster to wash down the cladding. Refer to your paint manufacturer for washing down requirements.
- Re-coating exterior protective finishes. Always refer to your paint manufacturer for re-coating requirements
- Regular inspection and repair if necessary of the cladding joints, sealants, fillers, flashings etc
- Cleaning out gutters, blocked pipes and overflow pipes as required
- Pruning back vegetation close to or touching the Hardie™ Plank Weatherboard 7.5mm
- Remove any snow or ice build up that is in direct contact with the cladding for extended periods
- The clearances between the bottom edge of Hardie™ Plank Weatherboard 7.5mm and the finished/unfinished ground must always be maintained eg around concrete paths/drives etc 100mm minimum and natural ground/pebbles etc 175mm minimum

11 Details

Various details outlined in the following table are available on Pages 23 to 53.

| Description | Page |
|---|-------------|
| Figure 1: Direct fix framing setout | 23 |
| Figure 2: Direct fix sheet fixing setout | 24 |
| Figure 3: Direct fix concrete footing | 25 |
| Figure 4: Direct fix weatherboard fixing | 26 |
| Figure 5: Direct fix aluminium external box corner | 27 |
| Figure 6: Direct fix external boxed corner | 27 |
| Figure 7: Direct fix external corner soaker | 28 |
| Figure 8: Direct fix internal 90° aluminium 'W' mould | 28 |
| Figure 9: Direct fix internal 135° aluminium 'W' mould | 29 |
| Figure 10: Direct fix soffit detail | 29 |
| Figure 11: Direct fix window sill flashings without facings | 30 |
| Figure 12: Direct fix one piece head flashing without facings | 31 |
| Figure 13: Direct fix jamb flashing without facings | 32 |
| Figure 14: Cavity framing and batten setout | 33 |
| Figure 15: Cavity framing batten fixing | 34 |
| Figure 16: Cavity weatherboard fixing setout | 35 |
| Figure 17: Cavity footing | 36 |
| Figure 18: Cavity weatherboard fixing | 37 |
| Figure 19: Cavity aluminium external box corner | 38 |
| Figure 20: Cavity boxed corner | 38 |
| Figure 21: Cavity external corner soaker | 39 |
| Figure 22: Cavity internal 90° aluminium 'W' mould | 40 |
| Figure 23: Cavity internal 135° aluminium 'W' mould | 40 |
| Figure 24: Cavity soffit detail | 41 |
| Figure 25: Cavity sill flashing without facings | 42 |
| Figure 26: Cavity jamb flashing without facings | 43 |
| Figure 27: Cavity one piece head flashing without facings | 44 |
| Figure 28: Cavity sill flashing with facing | 45 |
| Figure 29: Cavity jamb flashing with facings | 46 |
| Figure 30: Cavity one piece head flashing with facings | 47 |
| Figure 31: Cavity framing and batten setout | 48 |
| Figure 32: Cavity parapet flashing | 49 |
| Figure 33: Cavity pipe penetration | 50 |
| Figure 34: Cavity one piece apron flashing joint | 51 |
| Figure 35: Garage door jamb | 52 |
| Figure 36: Garage jamb | 53 |

Figure 1: Direct fix framing setout

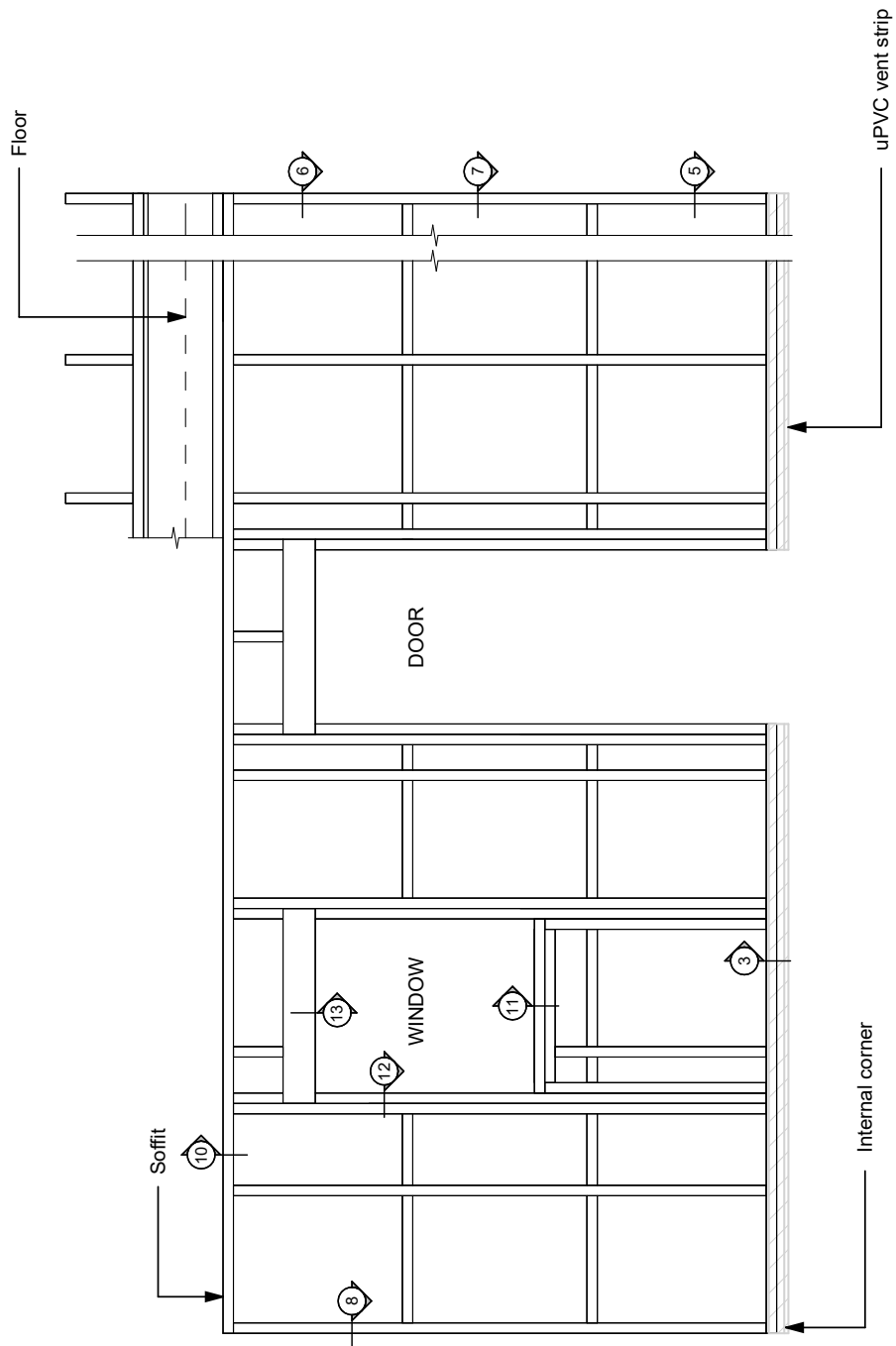

- Maximum stud spacing 600mm centres

Figure 2: Direct fix sheet fixing setout

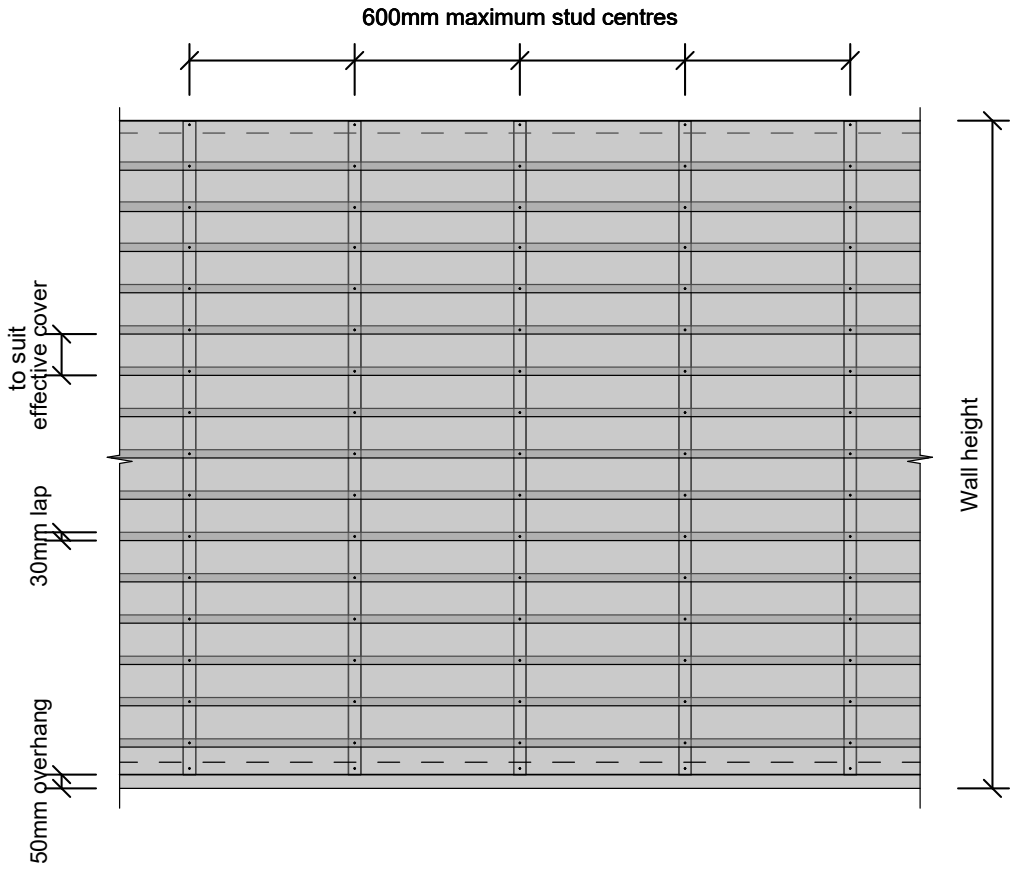
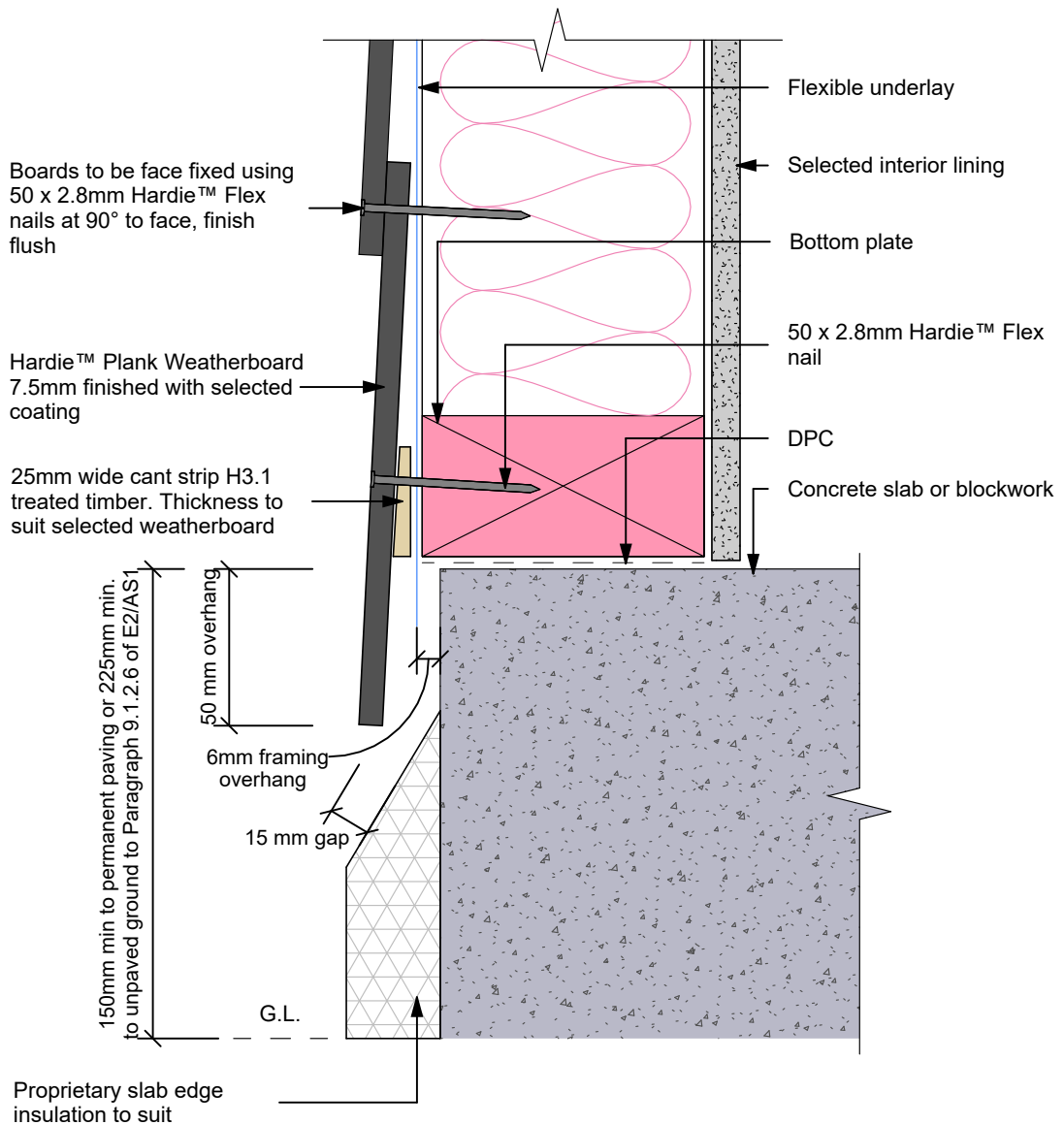

Figure 3: Direct fix concrete footing



Note:

- Site cut edges to be primed
- For uninsulated slab refer to jameshardie.co.nz

Figure 4: Direct fix weatherboard fixing

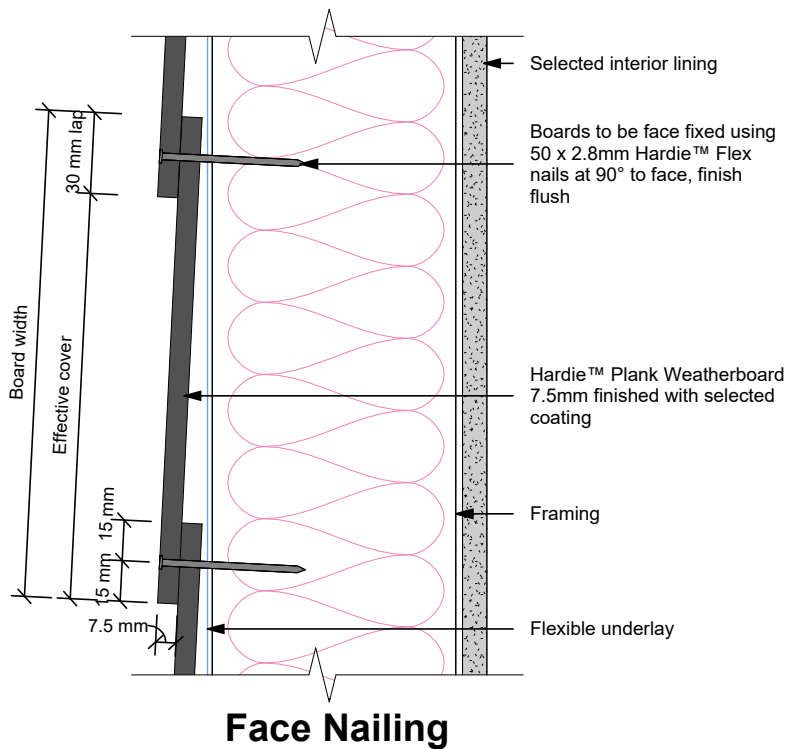
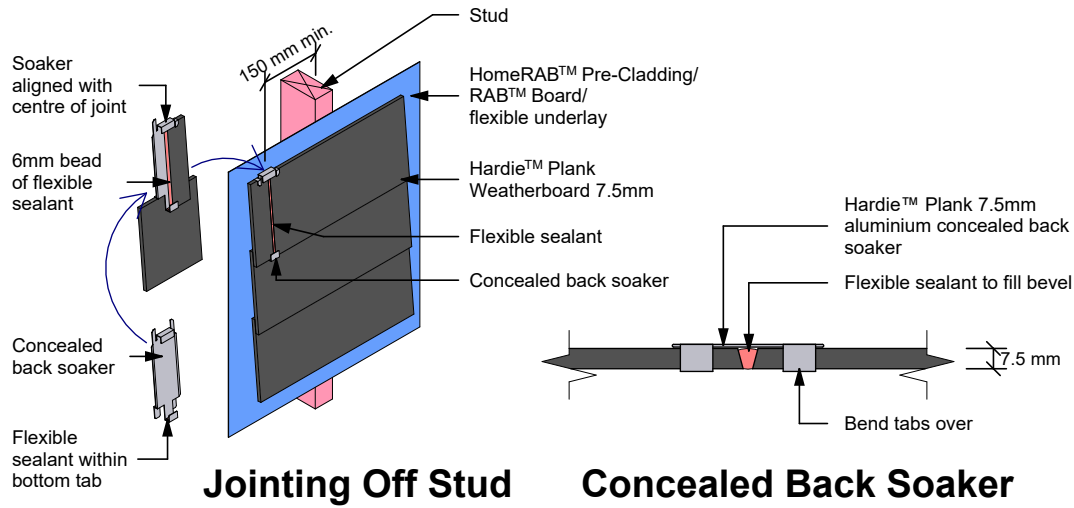

- Notes:
- Back soaker join in weatherboard to be 150mm minimum from side of stud. Joints must be staggered by 600mm minimum
 - Site cut edges to be primed
 - Push back soaker up to sit firm against bottom edge of Weatherboard

Figure 5: Direct fix aluminium external box corner

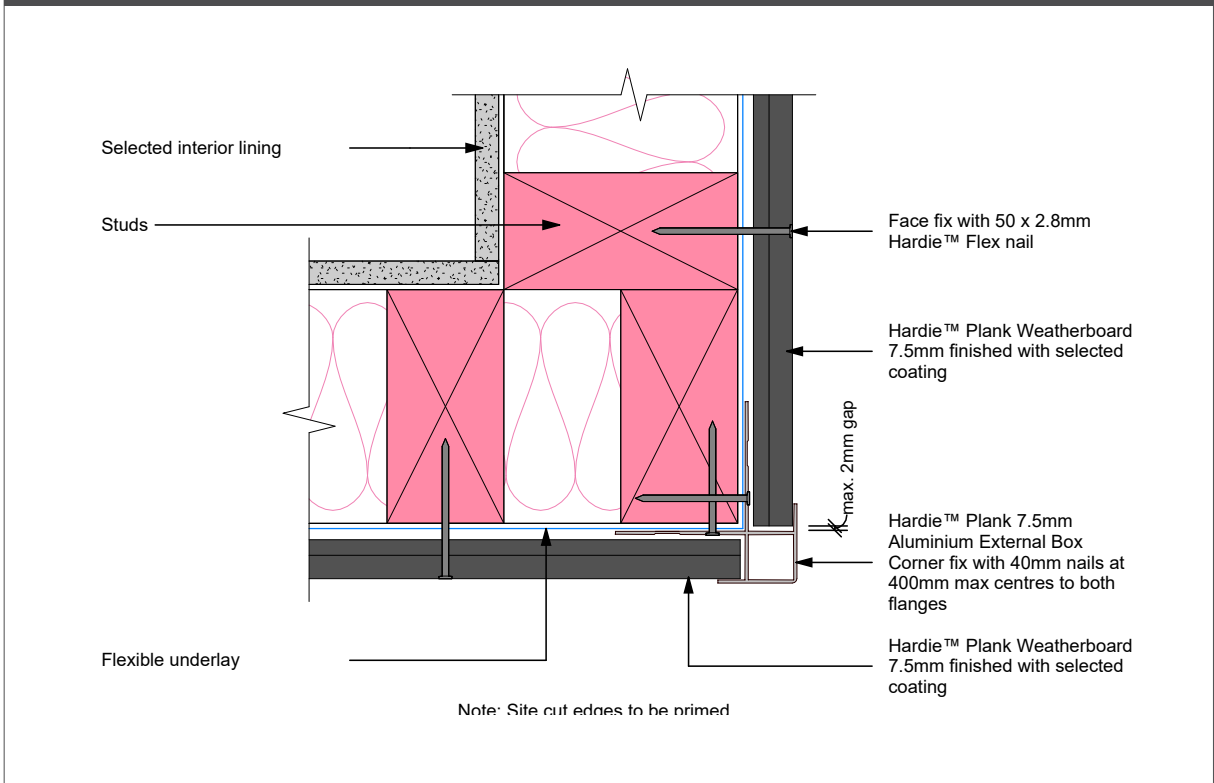

Figure 6: Direct fix external boxed corner

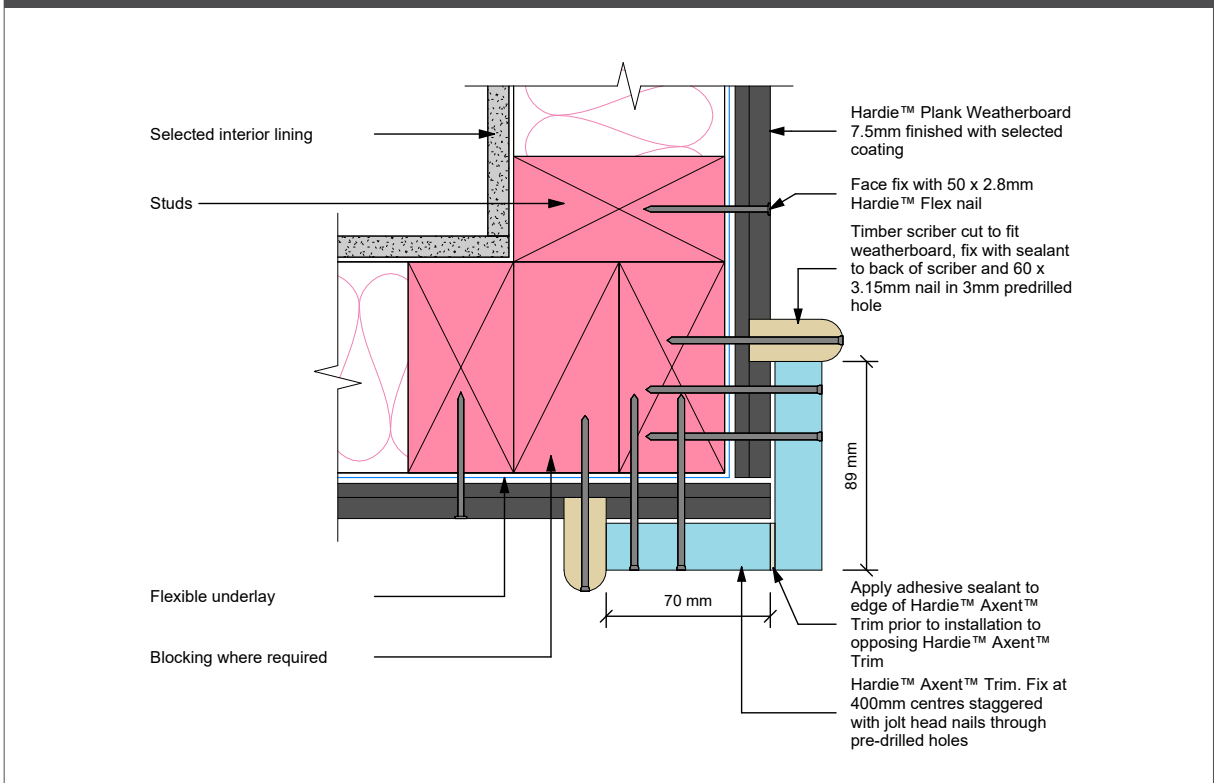

Figure 7: Direct fix external corner soaker

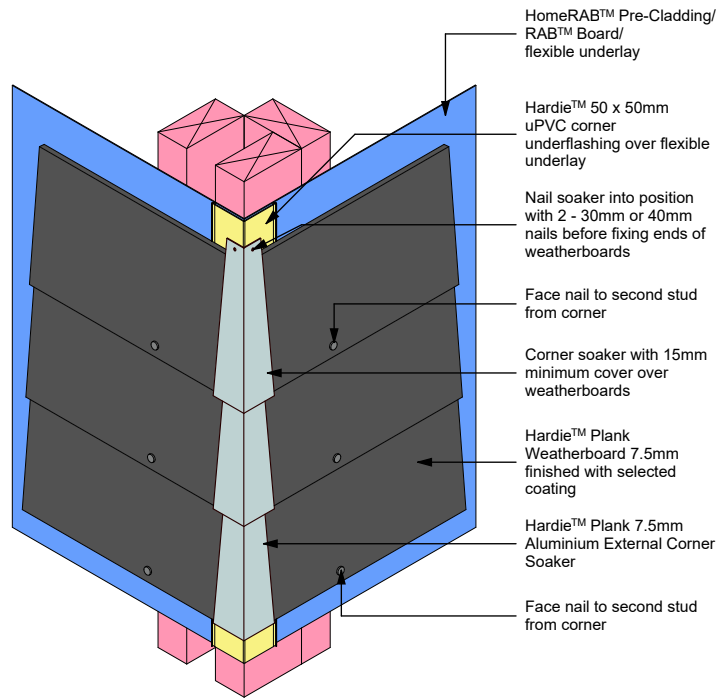

Figure 8: Direct fix internal 90° aluminium 'W' mould

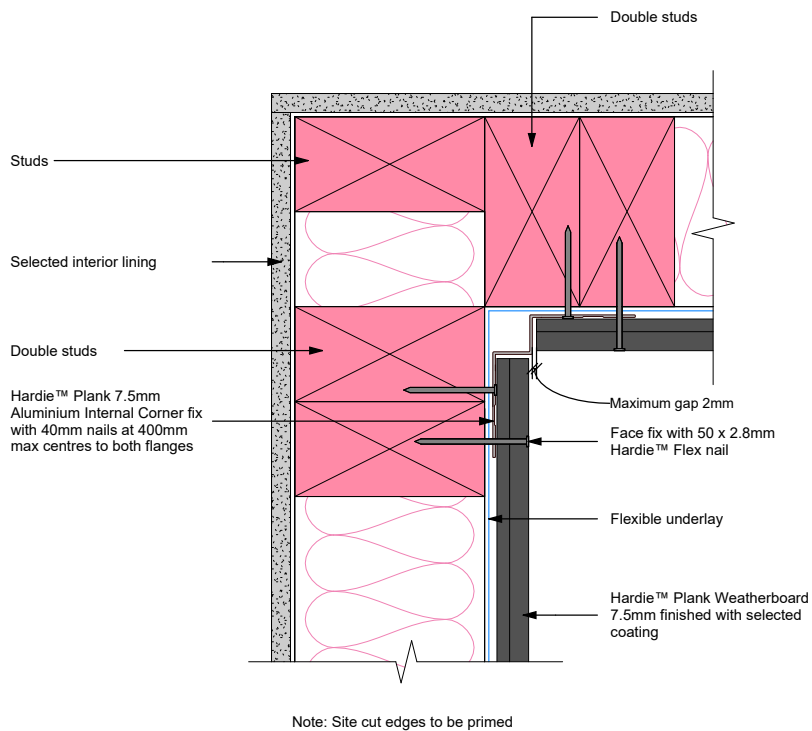

Figure 9: Direct fix internal 135° aluminium 'W' mould

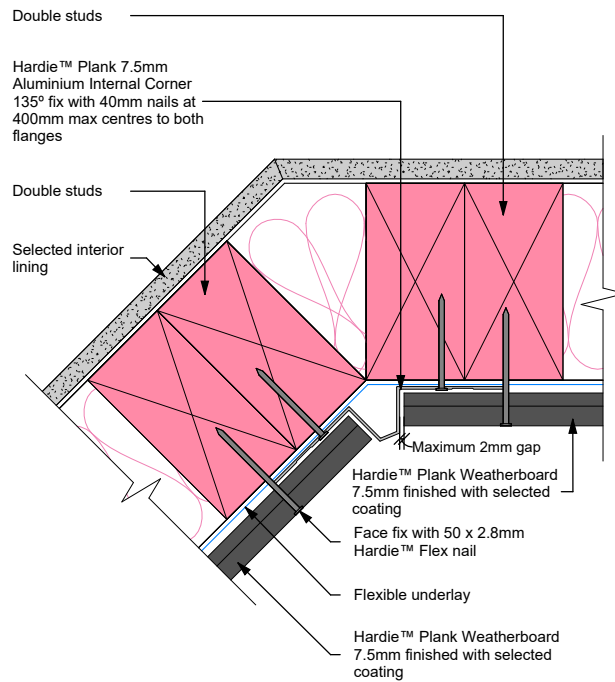

Figure 10: Direct fix soffit detail

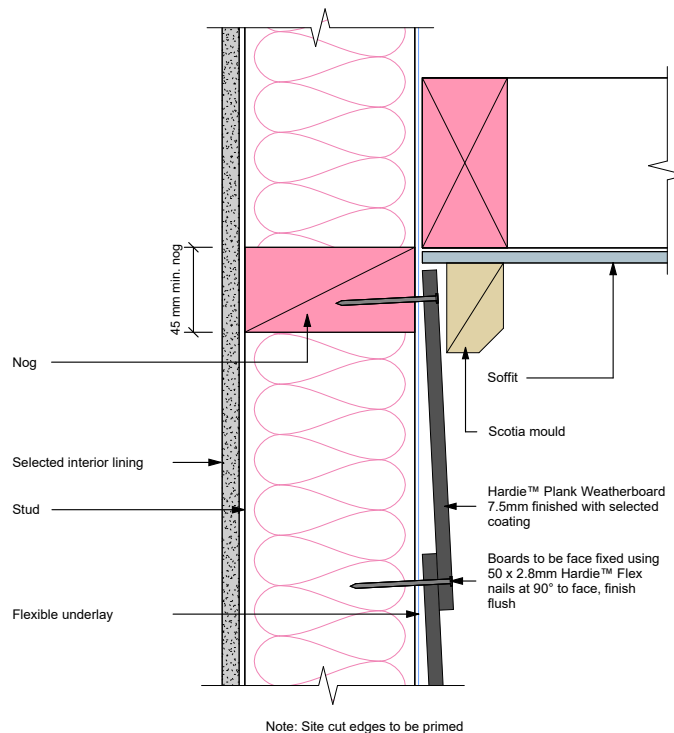
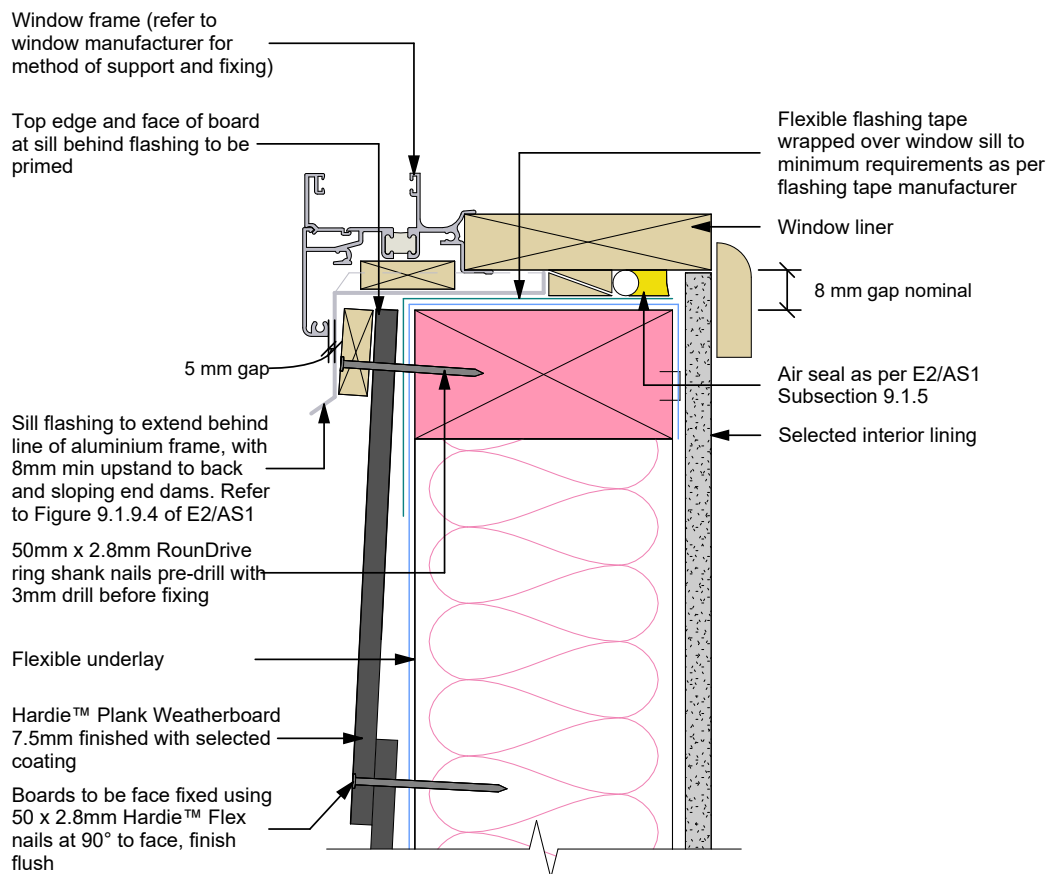

Figure 11: Direct fix window sill flashings without facings



General notes

1. Flashing materials must be selected based on environmental exposure, refer to the NZS 3604 and Table C1.1.1A of the NZBC E2/AS1
2. Flexible underlay must comply with acceptable solution E2/AS1
3. Flashing tape must have proven compatibility with the selected flexible underlay and other materials with which it comes into contact
4. When HomeRAB™ Pre-Cladding/RAB™ Board is used flashing tape to be applied to the entire window opening
5. Site cut edges to be primed

Figure 12: Direct fix one piece head flashing without facings

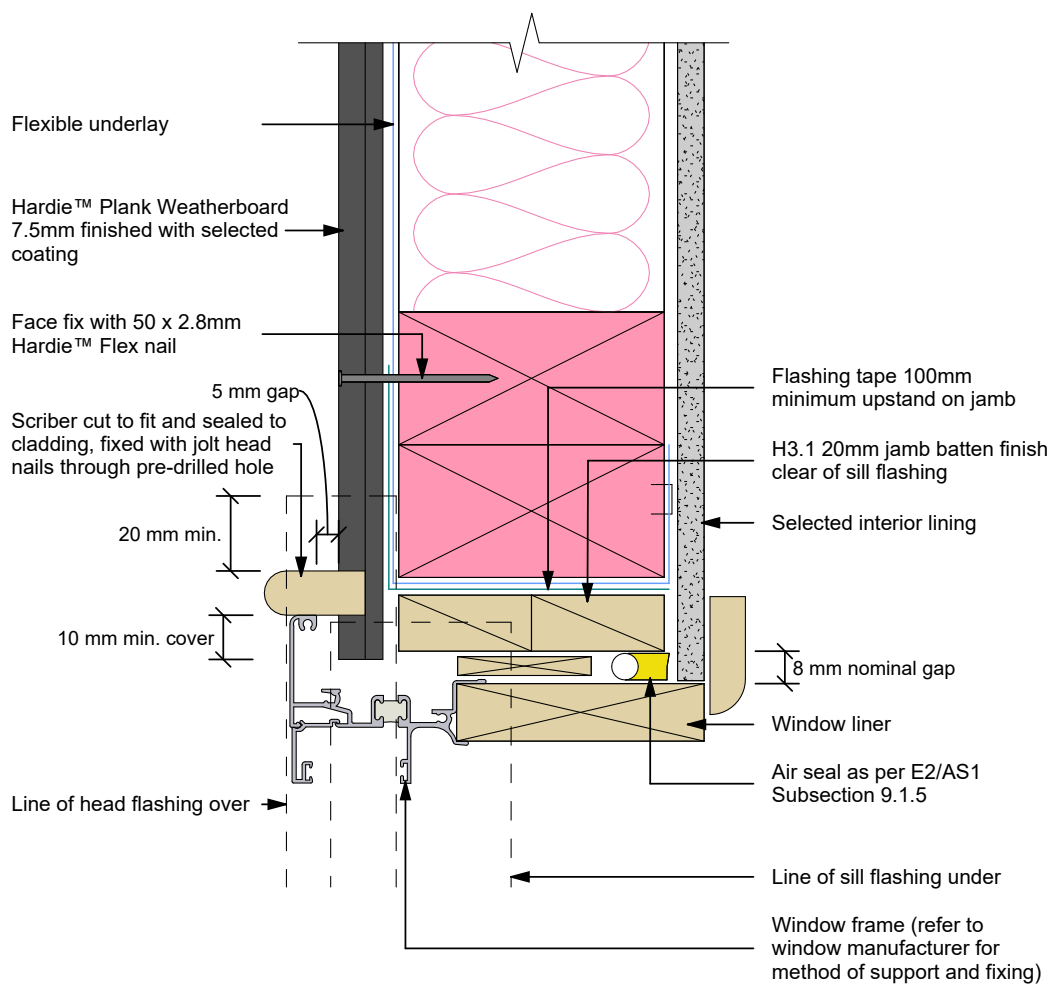
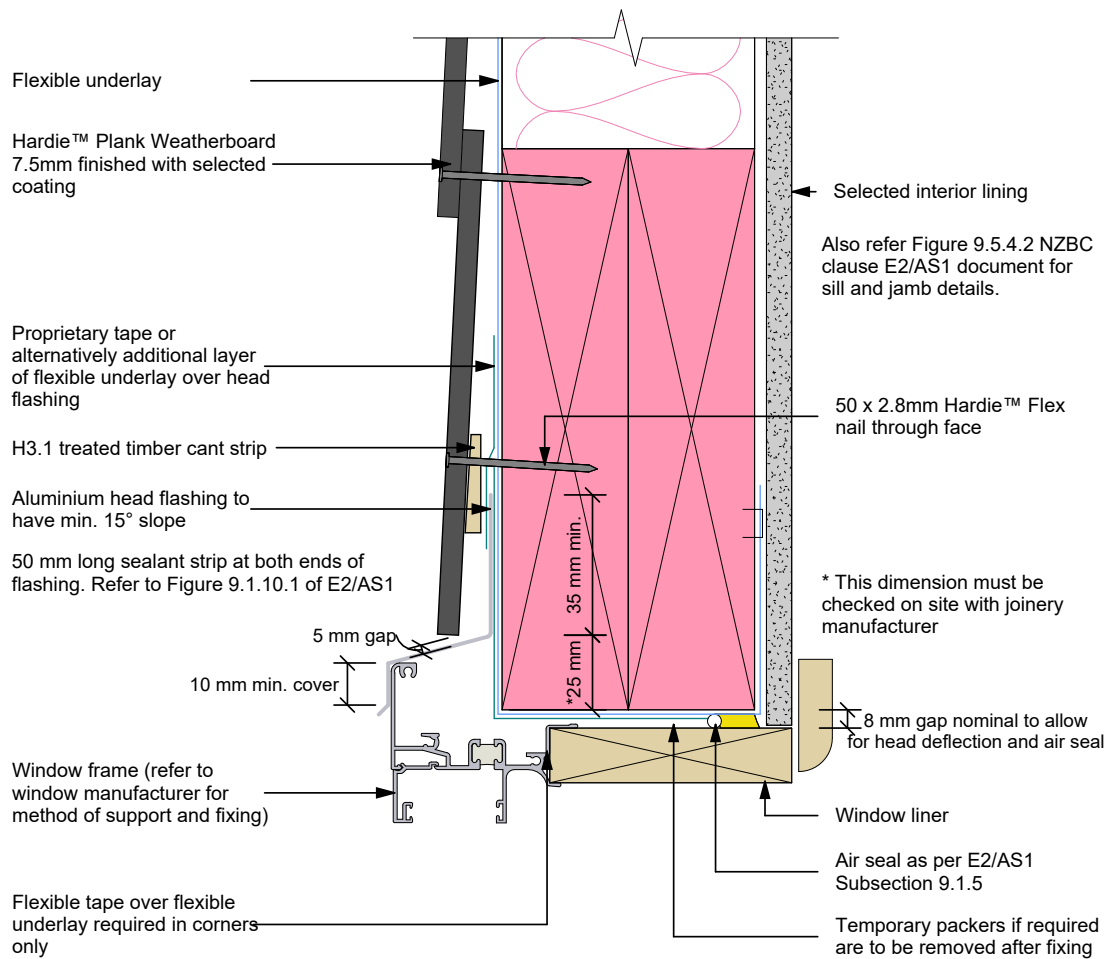
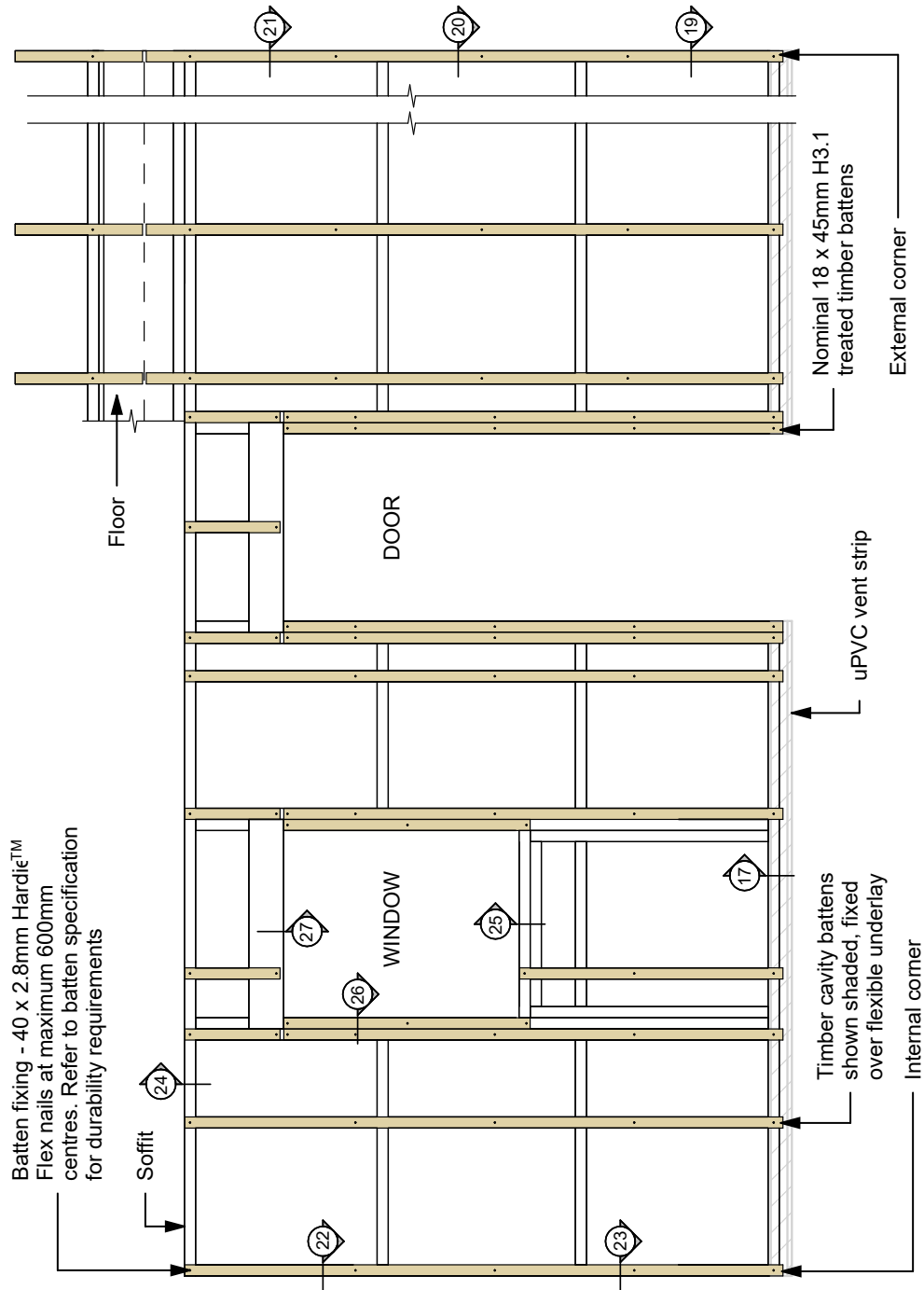

Figure 13: Direct fix jamb flashing without facings



Note:
Sealant must be installed between head flashing and window
flange in VH wind zones. Refer Figure 9.1.10.1 of E2/AS1

Figure 14: Cavity framing and batten setout



- Notes:
- Section notations refer to Figure numbers
 - Maximum stud spacing 600mm centres

Figure 15: Cavity framing batten fixing

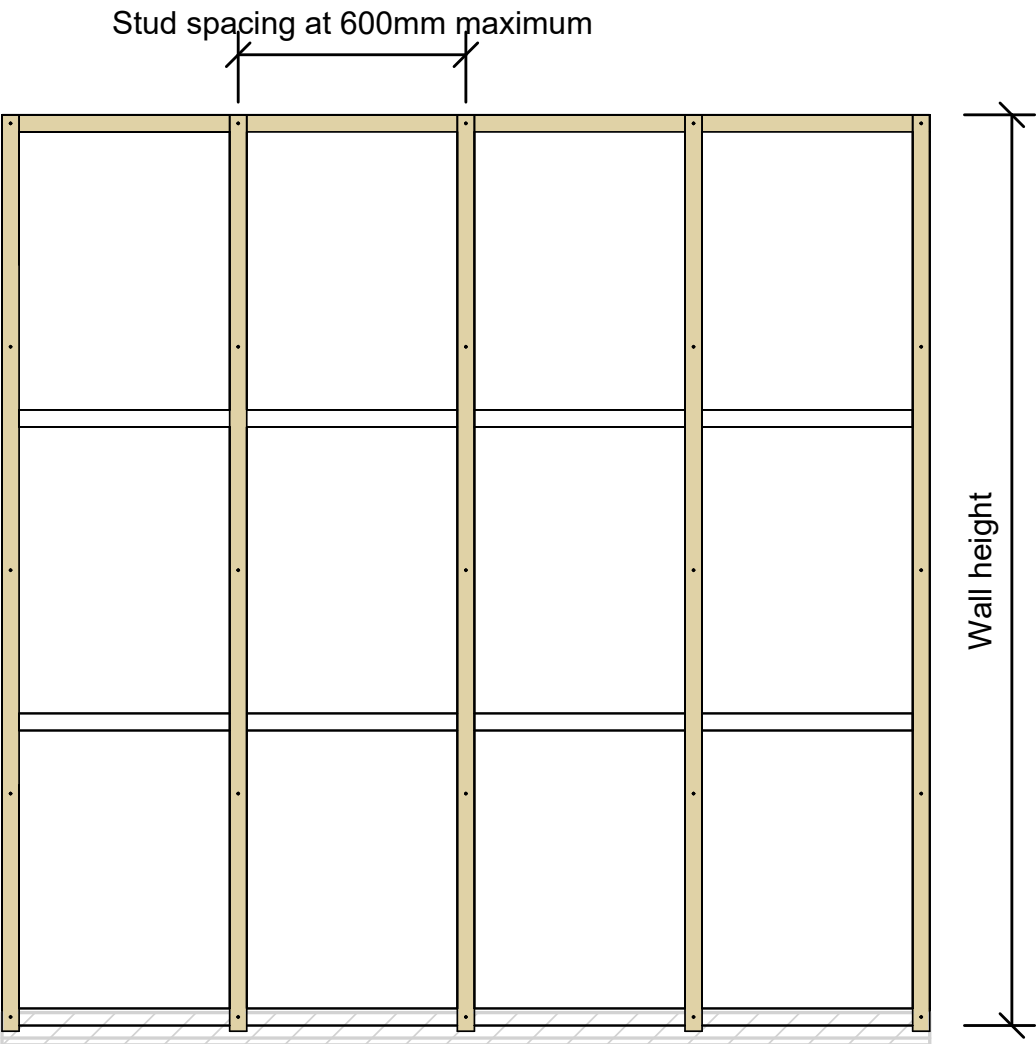

Figure 16: Cavity weatherboard fixing setout

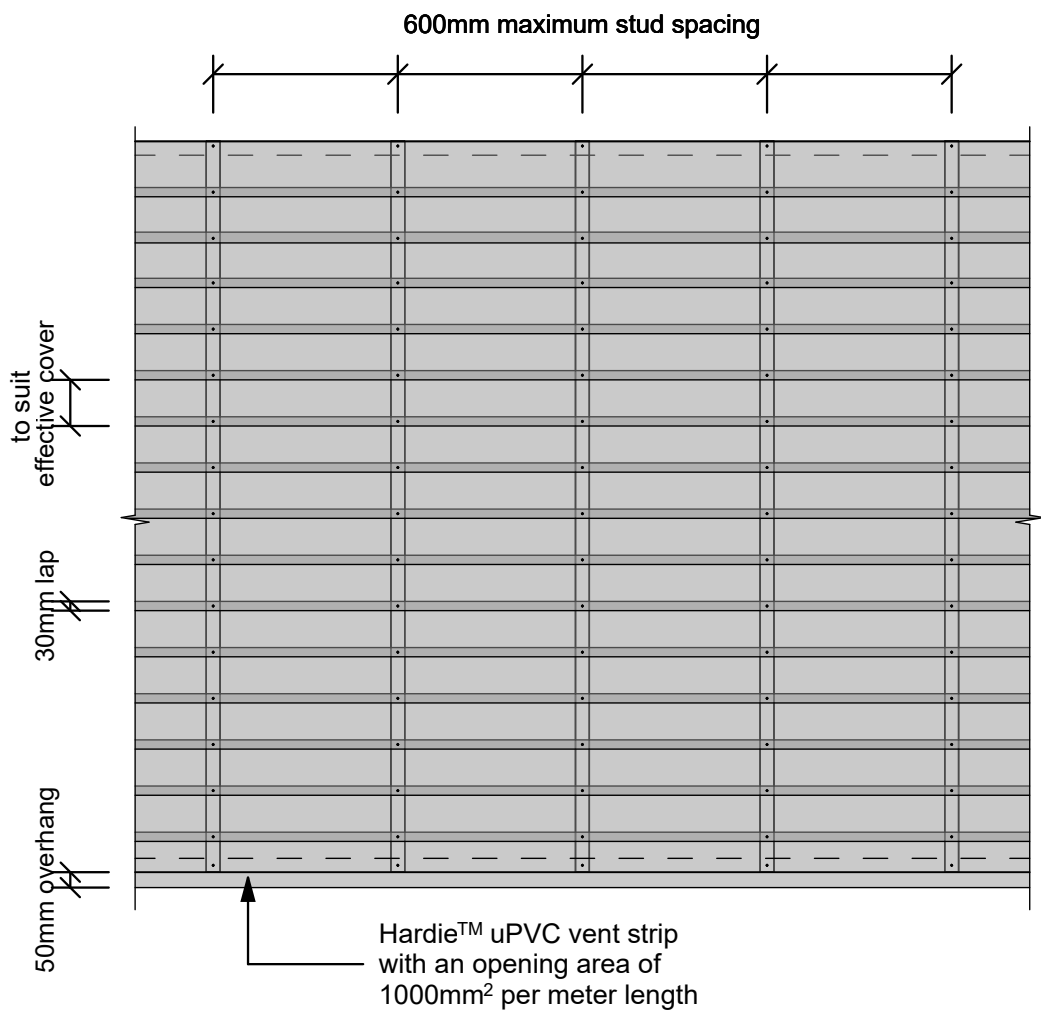
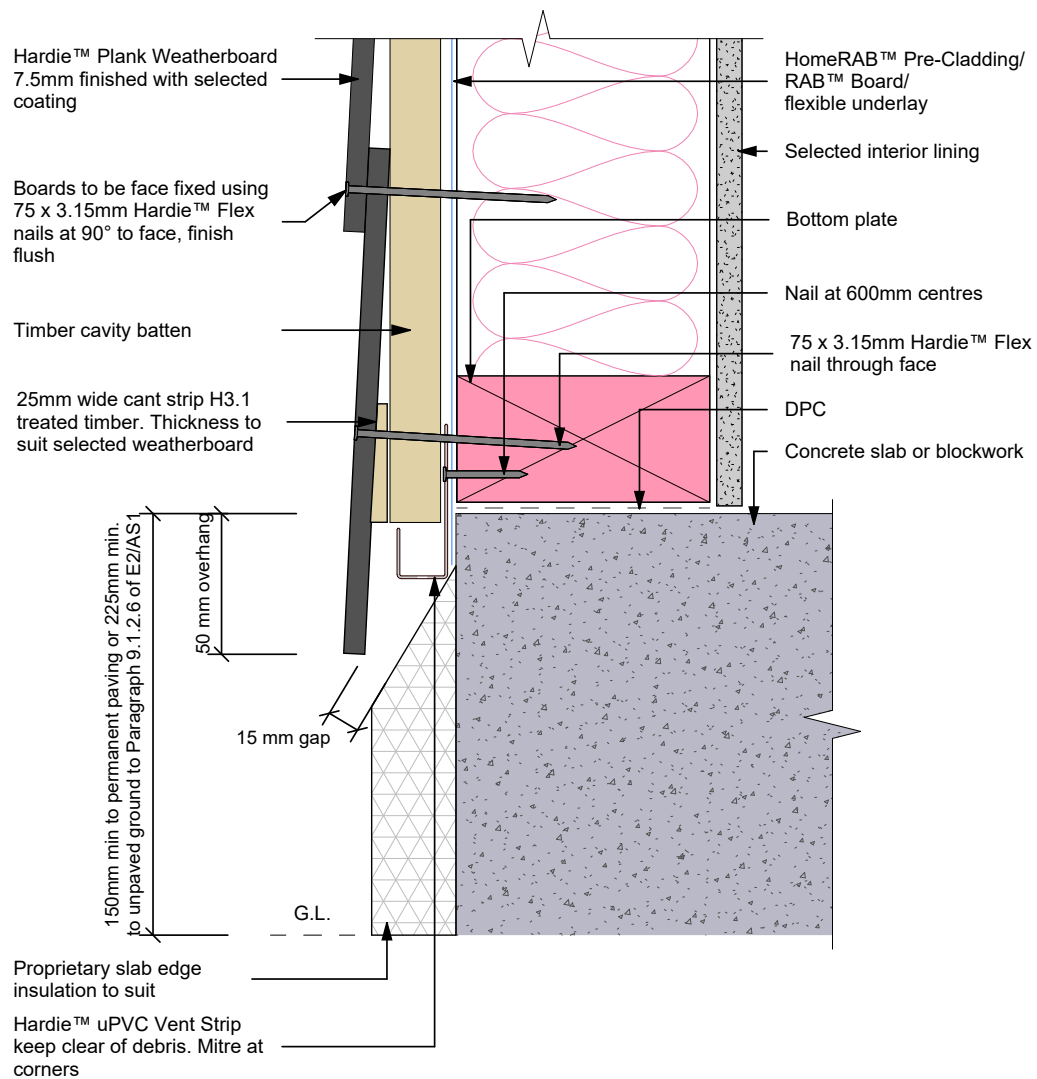
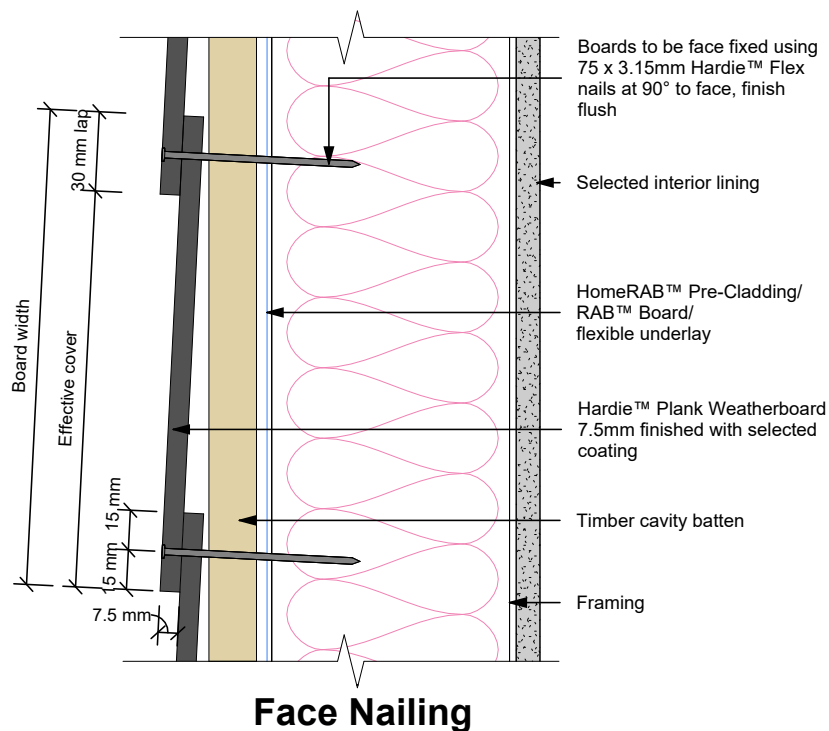
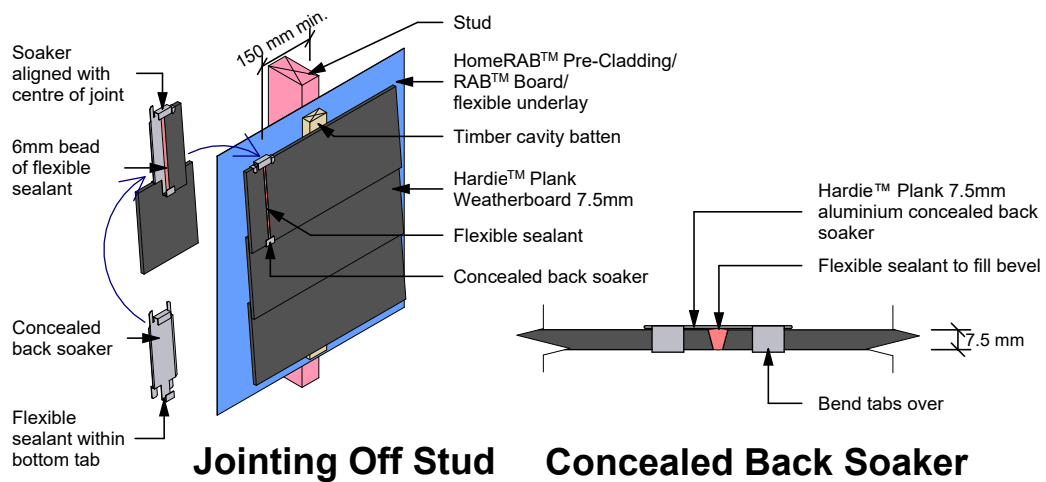

Figure 17: Cavity footing



- Note:
- Site cut edges to be primed
 - For uninsulated slab refer to jameshardie.co.nz

Figure 18: Cavity weatherboard fixing



Notes:

- Back soaker join in weatherboard to be 150mm minimum from side of stud. Joints must be staggered by 600mm minimum
- Site cut edges to be primed
- Push back soaker up to sit firm against bottom edge of Weatherboard

Figure 19: Cavity aluminium external box corner

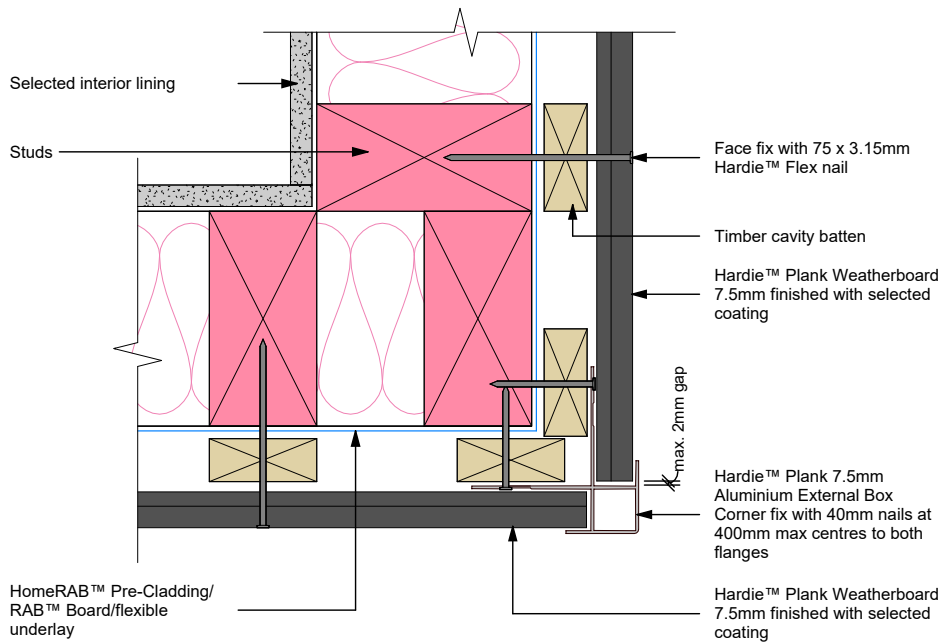

Note: Site cut edges to be primed

Figure 20: Cavity boxed corner

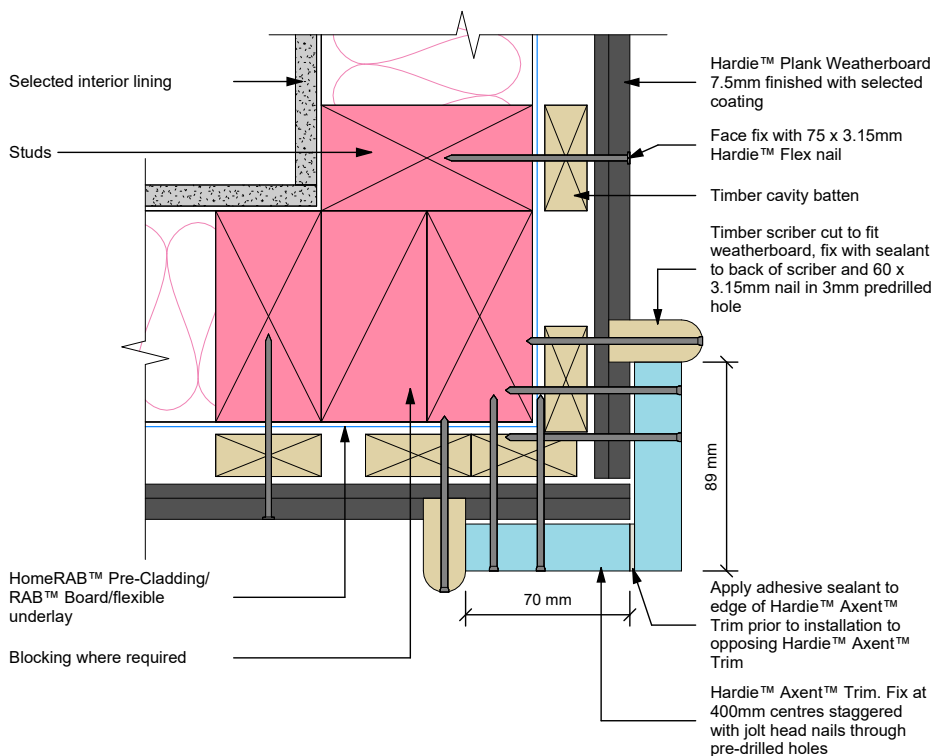

Figure 21: Cavity external corner soaker

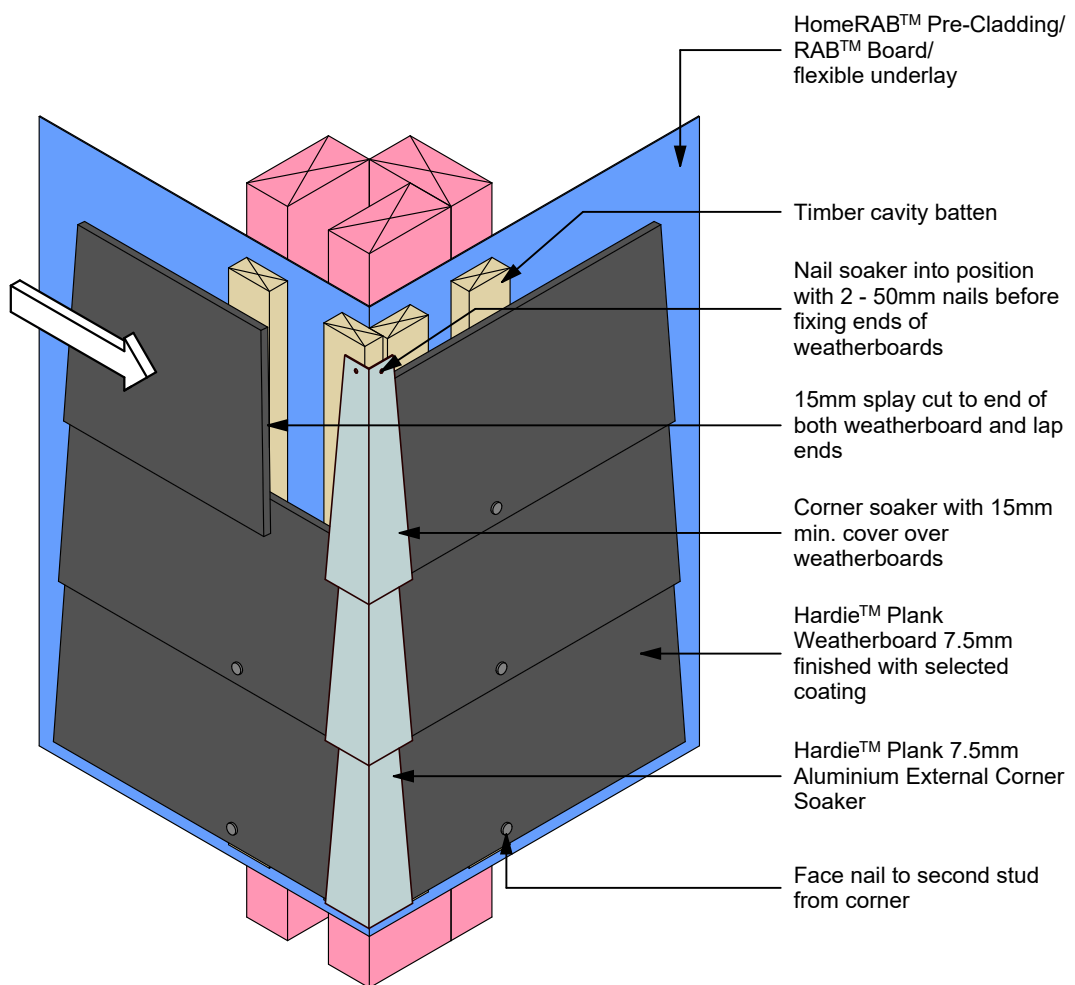

Figure 24: Cavity soffit detail

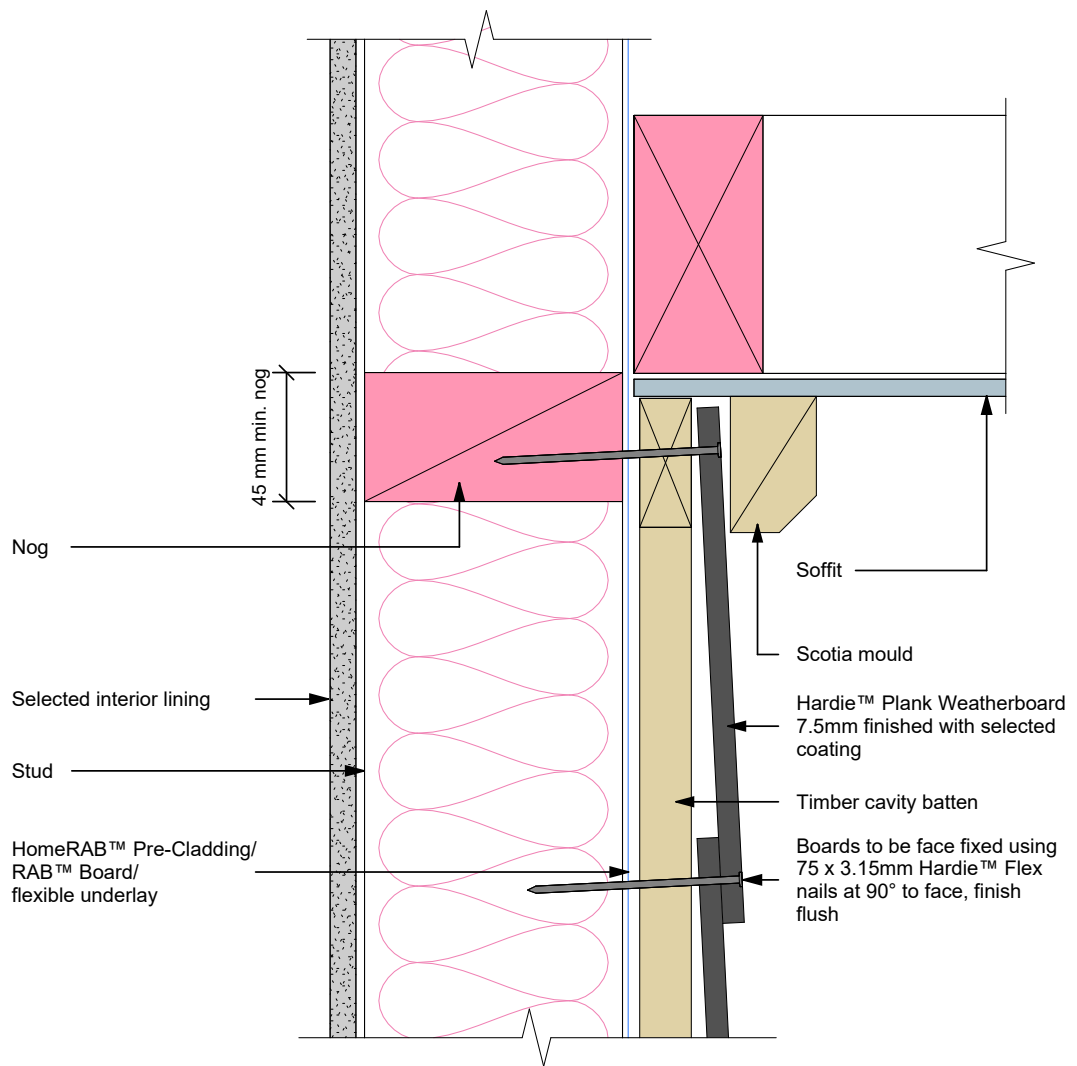
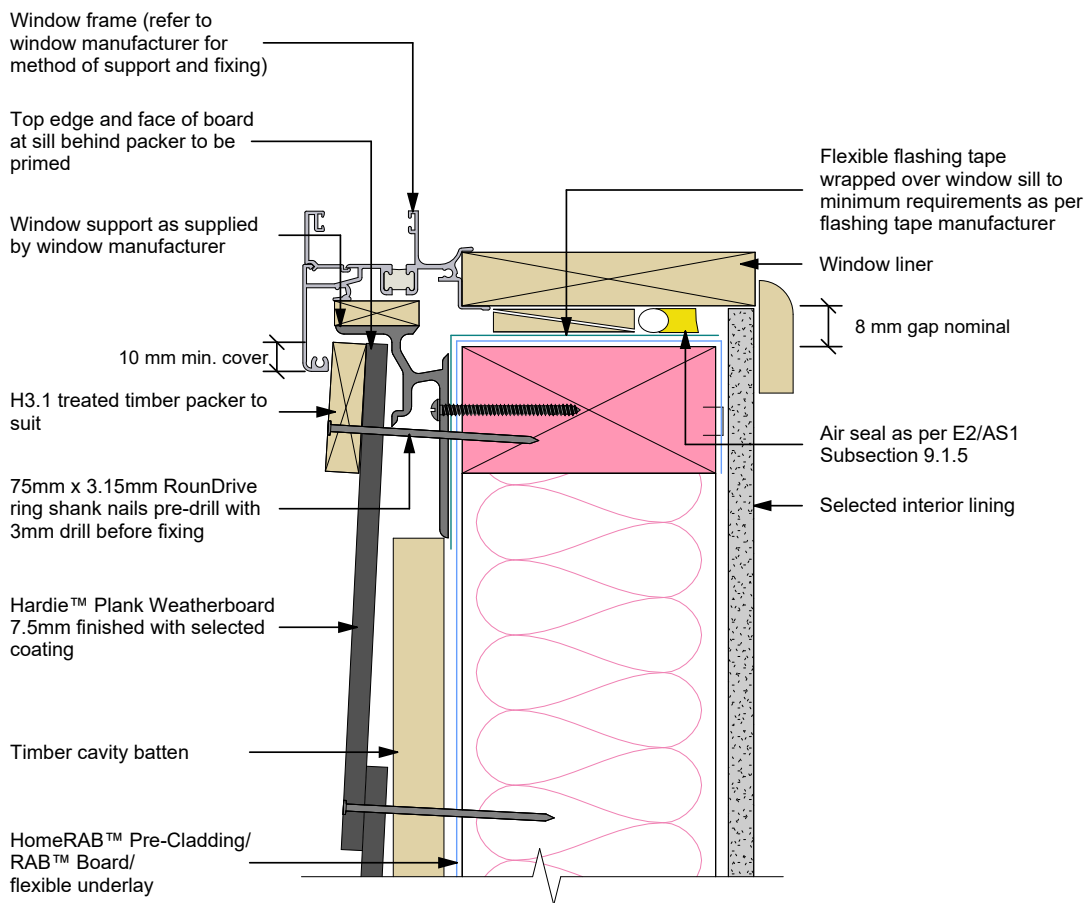

Figure 25: Cavity sill flashing without facings



General notes for materials selection

- Flexible underlay must comply with acceptable solution E2/AS1.
- Flashing tape must have proven compatibility with the selected flexible underlay and other materials with which it comes into contact.
- Also refer to Figure 9.5.4.3 of the NZBC clause E2/AS1 for jamb and head details

Refer to the manufacturer or supplier for technical information for these materials.

Figure 26: Cavity jamb flashing without facings

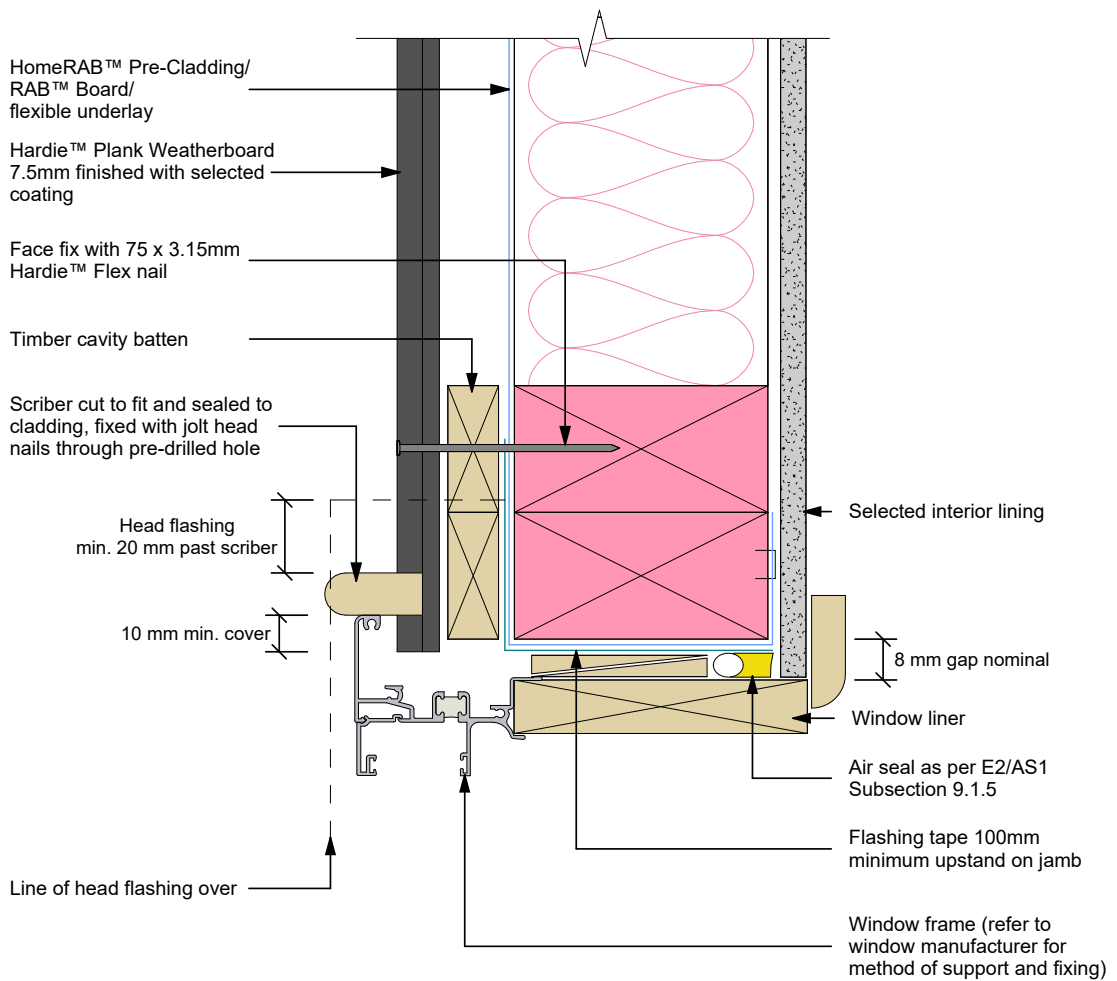

Notes:

- When HomeRAB™ Pre-Cladding/RAB™ Board is used flashing tape to be applied to the entire window opening.
- Also refer to Figure 9.5.4.3 of the NZBC clause E2/AS1 for sill and head details

Figure 27: Cavity one piece head flashing without facings

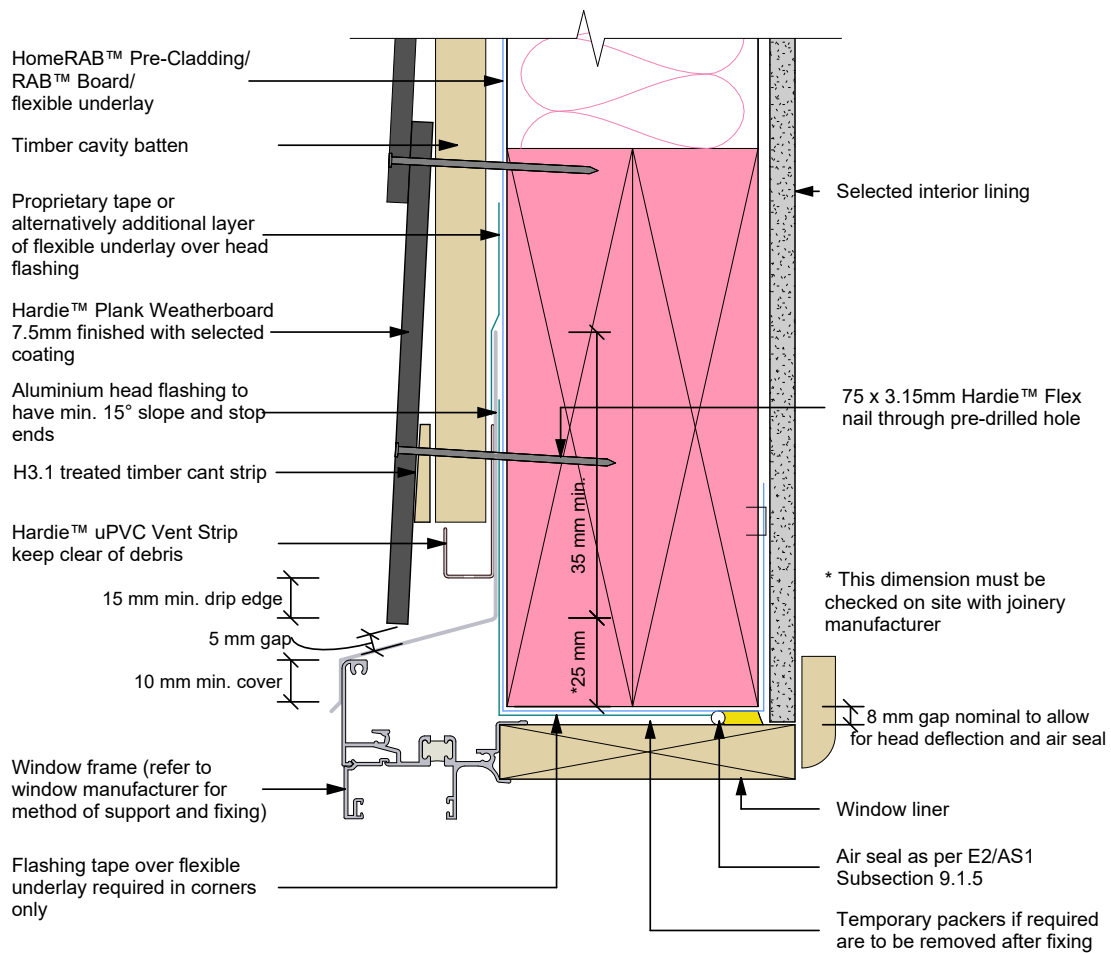

Notes:

- When HomeRAB™ Pre-Cladding/RAB™ Board is used flashing tape to be applied to the entire window opening
- Also refer to Figure 9.5.4.3 of the NZBC clause E2/AS1 for sill and jamb details
- Sealant must be applied between head flashing and window flange in VH and EH wind zones

Figure 28: Cavity sill flashing with facing

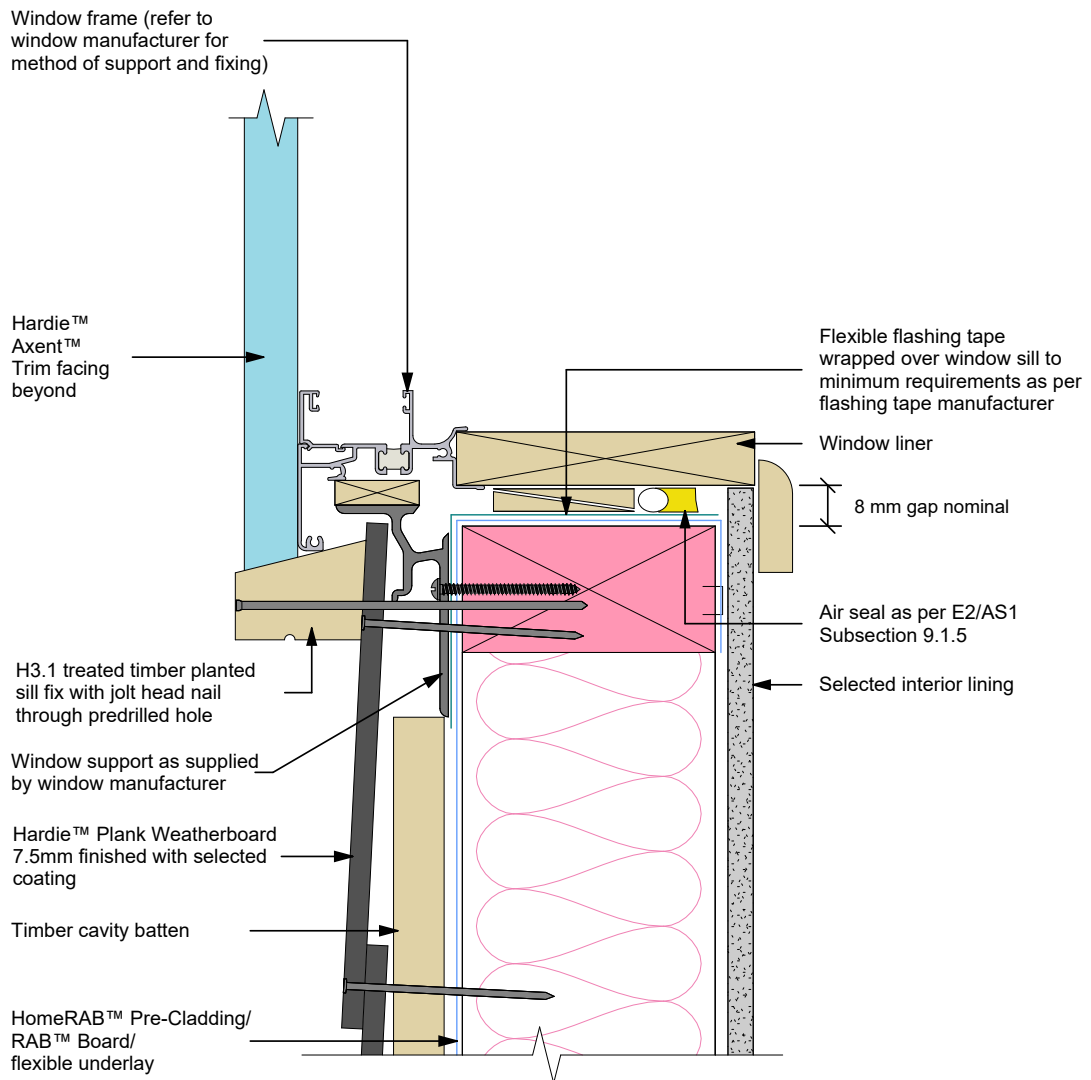

General notes for materials selection

- Flexible underlay must comply with acceptable solution E2/AS1.
- Flashing tape must have proven compatibility with the selected flexible underlay and other materials with which it comes into contact.

Refer to the manufacturer or supplier for technical information for these materials.

Figure 29: Cavity jamb flashing with facings

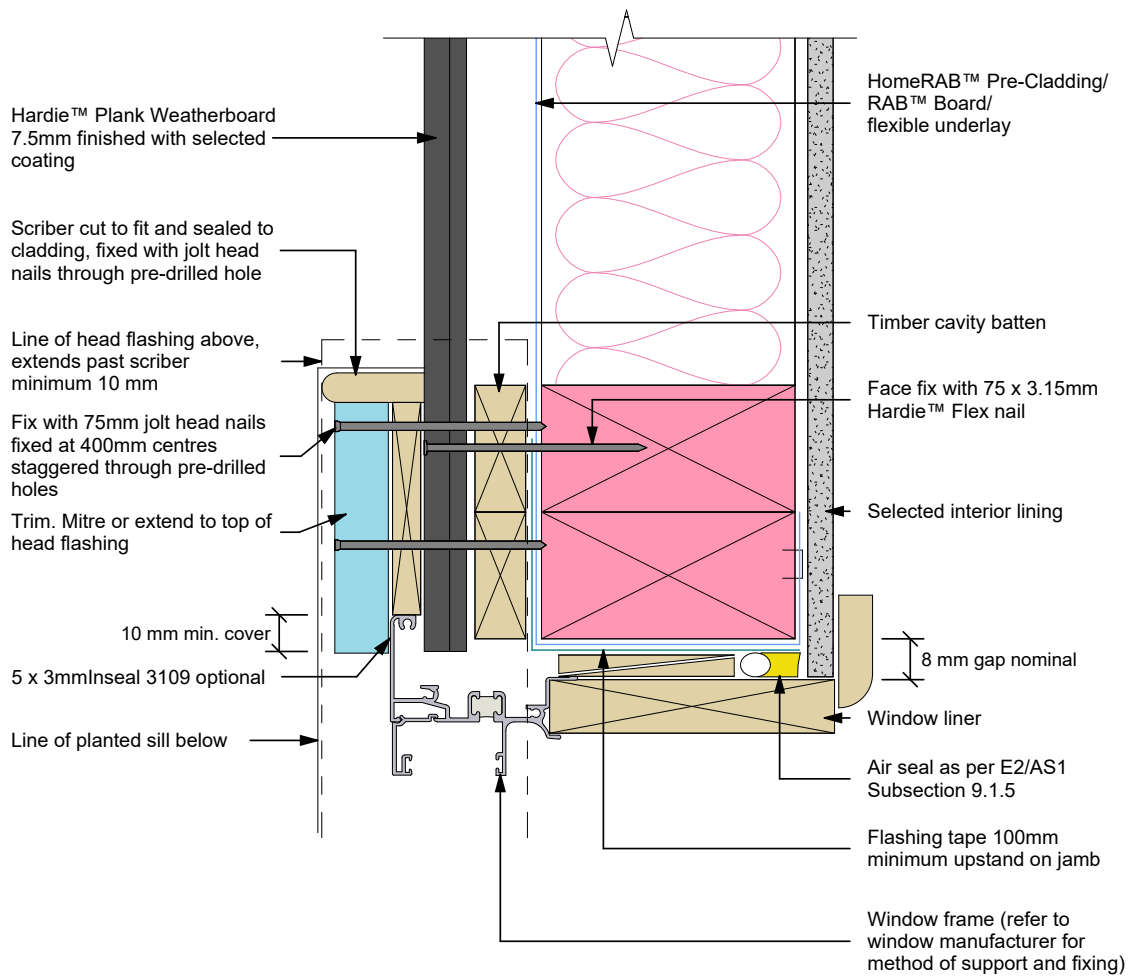

Note:

- When HomeRAB™ Pre-Cladding/RAB™ Board is used flashing tape to be applied to the entire window opening.

Figure 30: Cavity one piece head flashing with facings

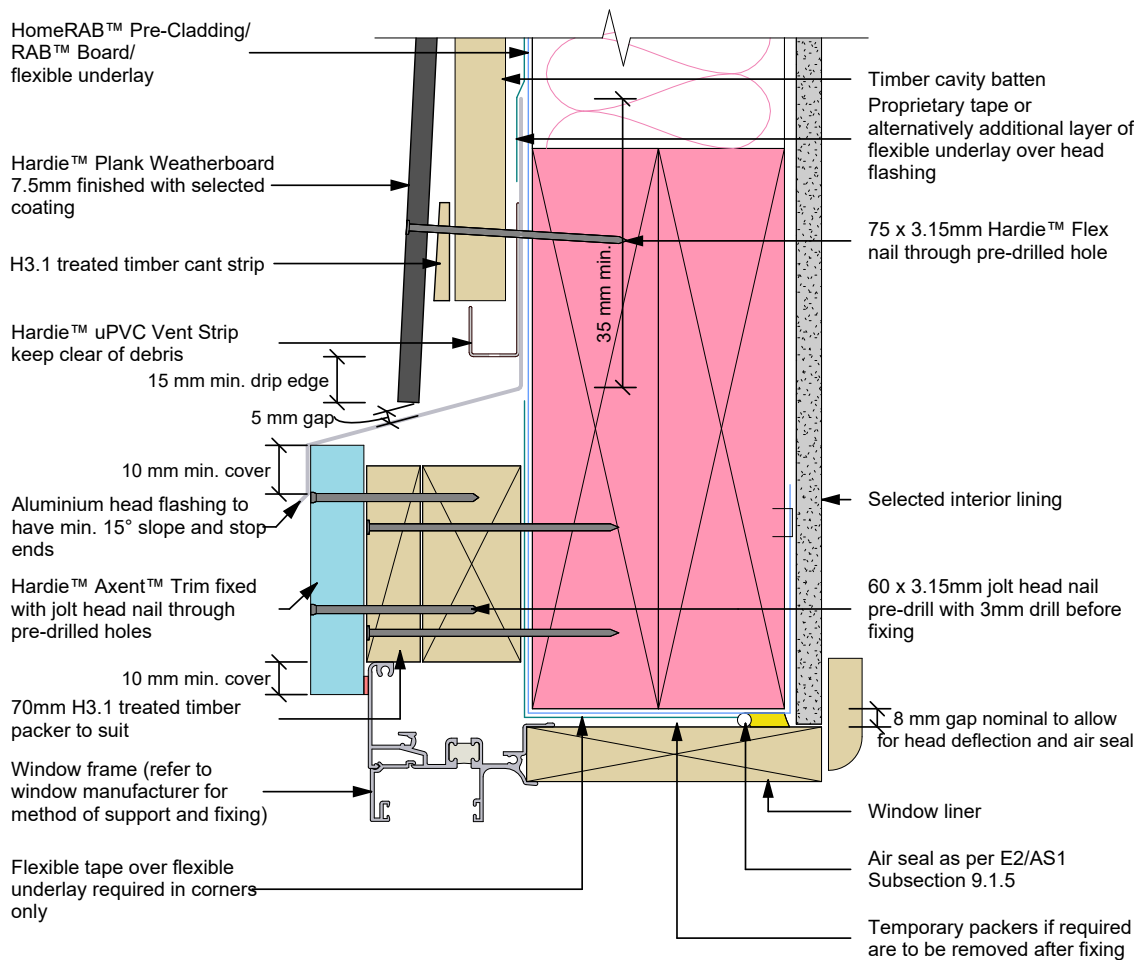

Notes:

- When HomeRAB™ Pre-Cladding/RAB™ Board is used flashing tape to be applied to the entire window opening
- Sealant must be installed between Hardie™ Axent™ Trim and window flange in VH and EH wind zones
- Sealant must be applied between the head flashing and Axent Trim in VH and EH wind zone.

Figure 31: Cavity framing and batten setout

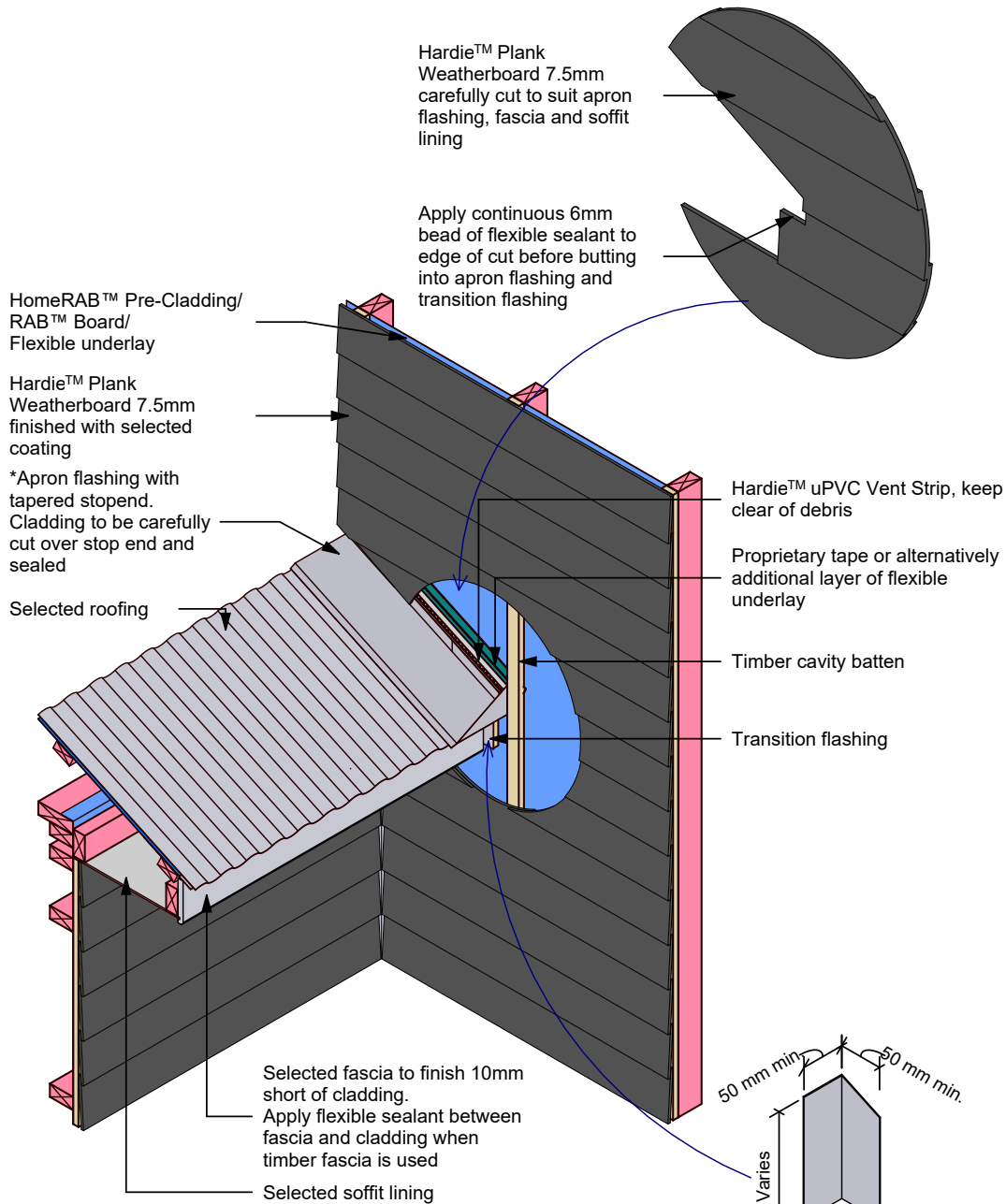

Note:

- Site cut edges to be primed
- Spouting omitted for clarity. End of spouting must be 10mm minimum clear of finished Hardie™ Plank Weatherboard 7.5mm
- Hardie™ Plank Weatherboard 7.5mm to be primed prior to fascia installation

*When 50 year durability for flashing is required refer to Table C.1.1.1A of the NZBC E2/AS1 document

Transition flashing Note: Height of transition flashing from top of fascia to underside of soffit lining

Figure 32: Cavity parapet flashing

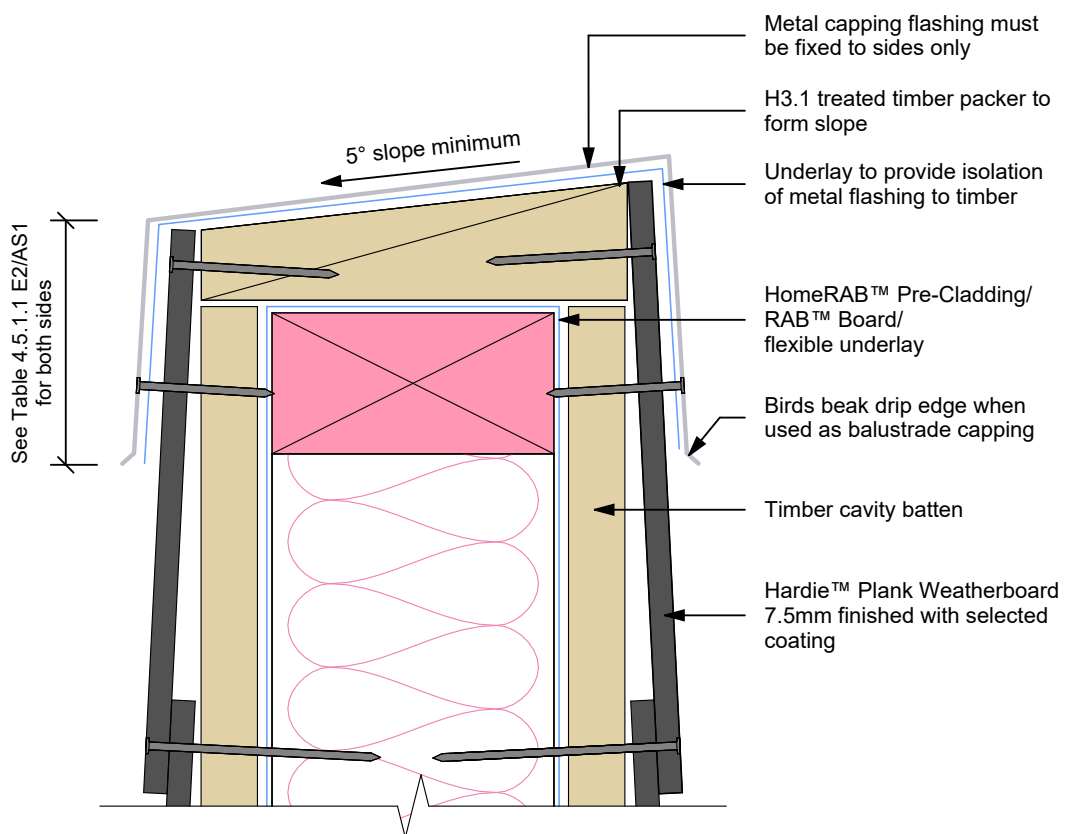
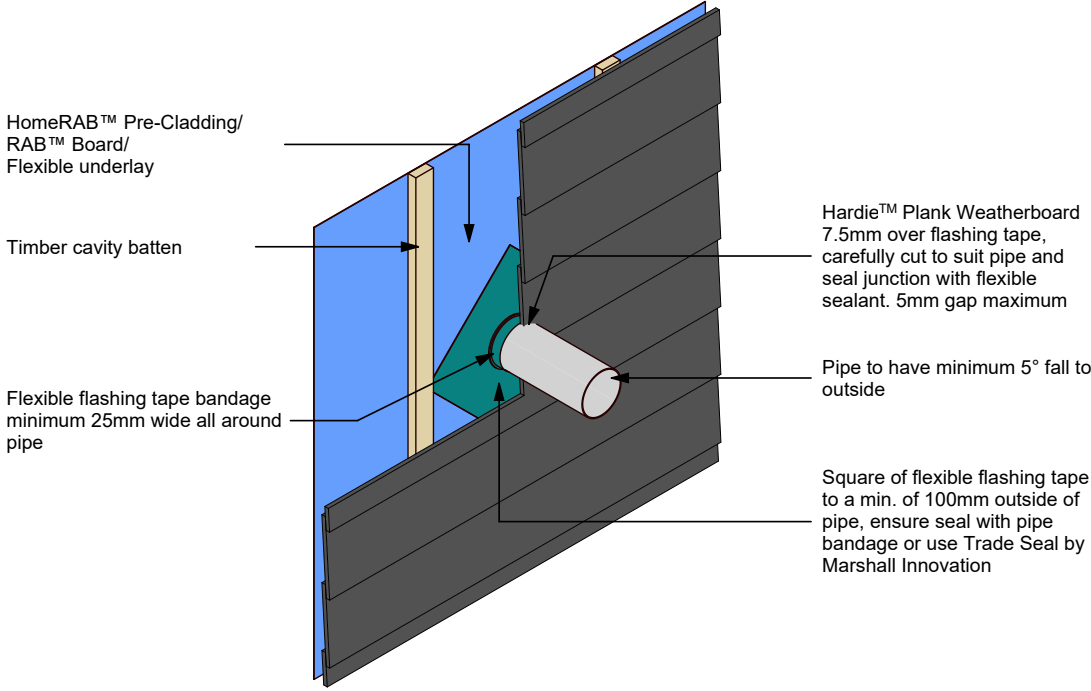

Figure 33: Cavity pipe penetration



Note:
All site cut edges to be primed

Figure 34: Cavity one piece apron flashing joint

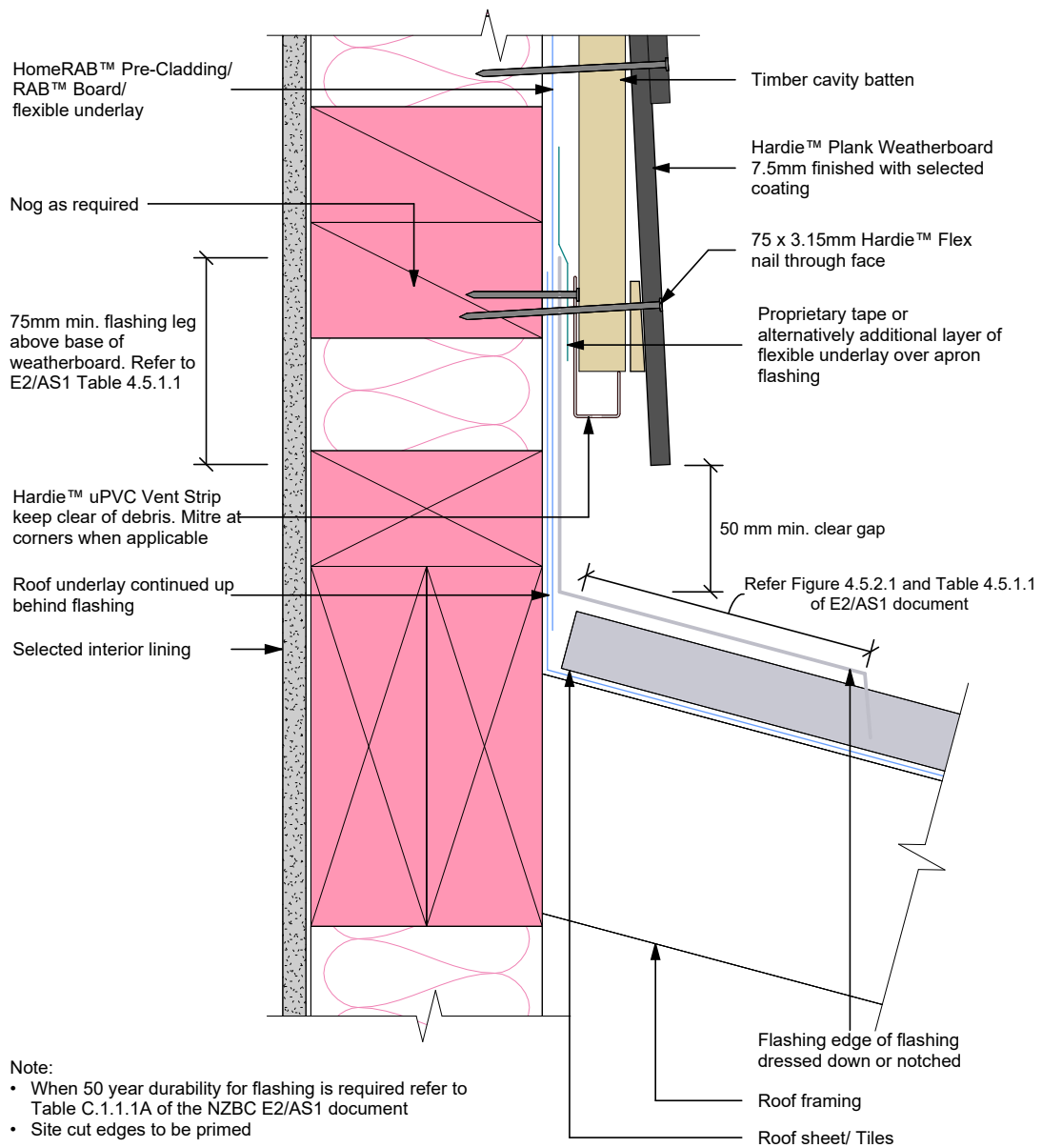

Figure 35: Garage door jamb

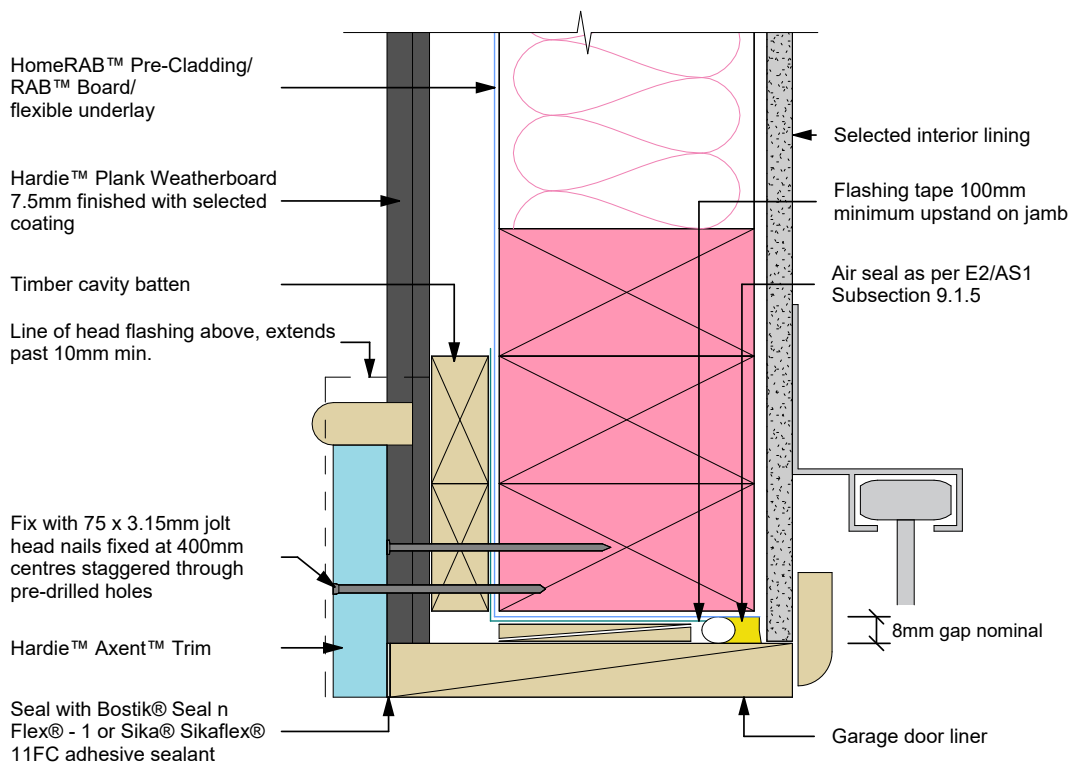
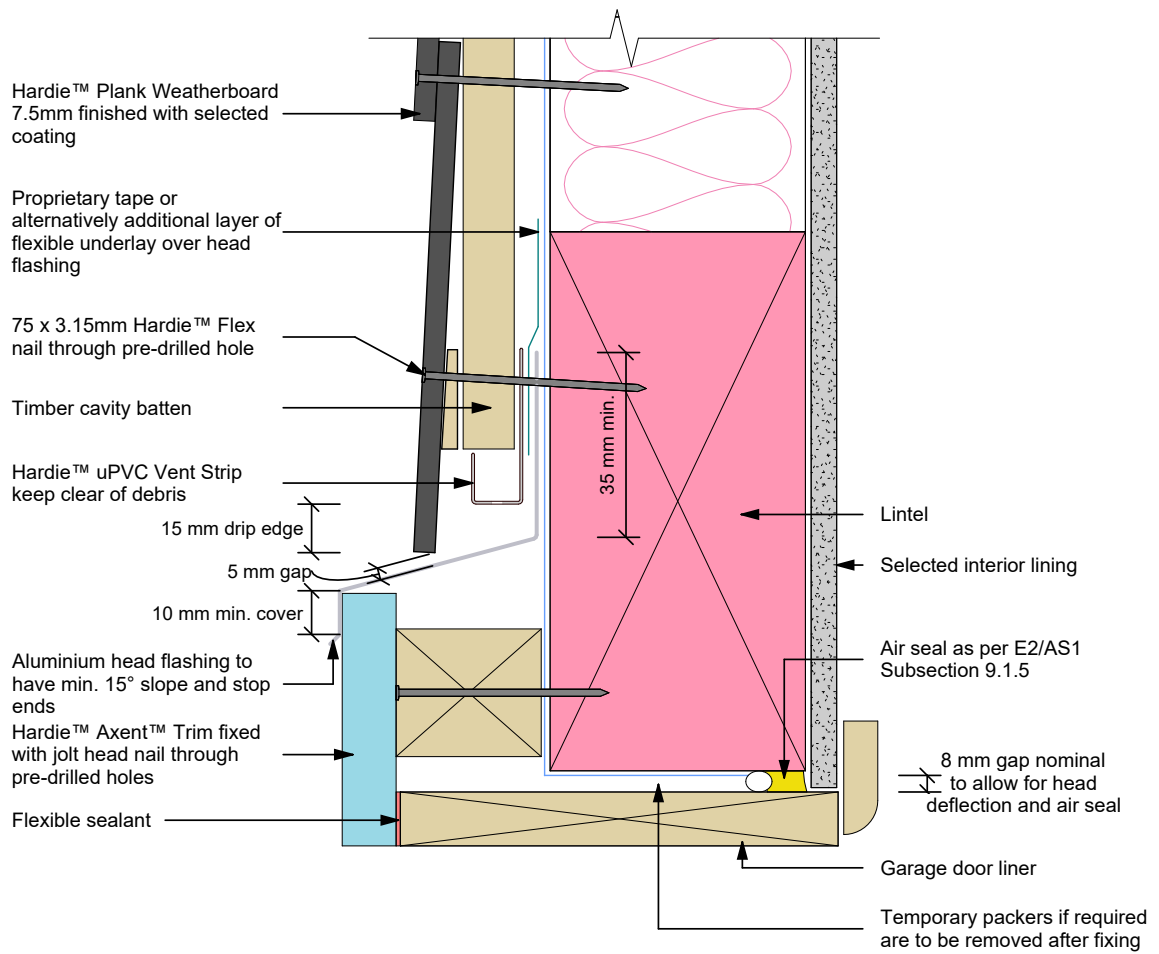

Figure 36: Garage jamb as per Linea Cavity



- Sealant must be applied between head flashing and Hardie™ Axent™ Trim in VH and EH wind zones
- Site cut edges to be primed

Product Warranty

NEW ZEALAND | Effective August 2024

This warranty is given by James Hardie New Zealand Limited (“James Hardie”, “we”, “its” and “us”).

In this warranty:

- **“Consumer”** has the meaning given to it in the Consumer Guarantees Act; ;
- **“Product”** refers to the item listed below:

Hardie™ Plank Weatherboard

- **“Technical Literature”** means the product specific installation guide published by James Hardie at the time of installation of the product (copies of the current installation instructions are available at jameshardie.co.nz or by calling Ask James Hardie™ on 0800 808 868); and
- **“Warranty Period”** means fifteen (15) years.

Warranty

1. Subject to the conditions and limitations set out below, we warrant that for the Warranty Period from the date of purchase, the Product will be free from defects due to defective factory workmanship or materials.
2. James Hardie further warrants that for a period of 15 years from the date of purchase of the Product that any associated accessories supplied by us will be free from defects due to defective factory workmanship or materials.
3. James Hardie warrants that at the time of manufacture the Product will comply with AS/NZS 2908.2:2000 Cellulose-cement products - Flat sheet.
4. This warranty is not transferable and is only provided to and may only be relied upon by:
 - (a) the first purchaser of the Product or accessory from James Hardie; and
 - (b) the last purchaser of the Product or accessory prior to installation.
5. If a breach of this warranty occurs, we will (at our option) either: supply replacement Product or accessory; rectify the affected Product or accessory; or pay for the reasonable and substantiated cost of the replacement or rectification of the affected Product or accessory.

Warranty Conditions

6. You may only claim under this warranty if:
 - (a) the Product was installed and maintained strictly in accordance with the Technical Literature including the components or products specified or recommended in the Technical Literature; and
 - (b) other products applied to or used in conjunction with the Product are applied or installed and maintained strictly in accordance with the relevant manufacturer’s instructions and good trade practice; and
 - (c) the Product is used in an application designed and constructed in strict compliance with all relevant provisions of the New Zealand Building Code (“**NZBC**”), applicable laws, regulations and standards; and
 - (d) we are given reasonable opportunity to inspect the Product **before** any attempt is made to repair or remove the Product once it has been installed; and
 - (e) the requirements for bringing a claim under the warranty as set out in clause 8 are complied with.

7. Subject to clauses 10 and 11:

- (a) to the fullest extent permitted by law, we exclude all:
 - (i) other warranties, conditions, liabilities and obligations which may otherwise apply in respect of the purchase or use of the Product and/or its Technical Literature, other than those specified in this warranty; and
 - (ii) liability for any loss or damage (whether direct or indirect) including property damage or personal injury, consequential loss, economic loss or loss of profits, the purchase or use of the Product and/or its Technical Literature whether arising in contract, tort (including negligence), statute or equity.
- (b) if or to the extent that it is not permitted by law to so limit our liability as set out in clause 7(a), then to the fullest extent permitted by law, we limit our liability at our option to:
 - (i) the replacement of the Product or accessory or the supply of equivalent Product or accessory;
 - (ii) the repair of the Product or accessory;
 - (iii) the payment of the cost of replacing the Product or accessory, or of acquiring equivalent Product or accessory; or
 - (iv) the payment of the reasonable and substantiated cost of having the Product or accessory repaired;
- (c) this warranty does not cover defects which are not due to defective factory workmanship or materials, including but not limited to damage or defects caused by or arising from or attributable to:
 - (i) use of the Product in applications not recommended by us or in accordance with the Technical Literature;
 - (ii) the Product being subjected to abnormal treatment including impact, abrasion or mechanical action;
 - (iii) surface marking, scratches or stains arising during or after the installation of the Product;
 - (iv) poor workmanship or installation, poor design or detailing, settlement or structural movement and/or movement of materials to which the Product is attached;
 - (v) incorrect design of the structure;
 - (vi) acts of God including but not limited to earthquakes, fire, cyclones, floods or other severe weather conditions or unusual climatic conditions;
 - (vii) efflorescence, normal wear and tear, growth of mould, mildew, fungi, bacteria, or any organism on any Product surfaces or Product (whether on the exposed or unexposed surfaces);

- (viii) contact with chemicals such as solvents, detergents and pollutants, or exposure to a harsh chemical environment or an excessively salty environment;
- (ix) use of adhesive tapes, sealants or mastics on the Product, or recoating of the surface of the Product outside of the recommended maintenance guidelines in the Technical Literature; or
- (x) failure of third party coating systems, including but not limited to sealers and paints; and
- (xi) **this warranty does not cover** any variation in the look of the Product including but not limited to: any variation in colour or surface pattern; any variation between different batches of the Product; or any variation against any sample material provided. The architect/builder/installer must ensure **prior to specification** that variation in look between items of Product is acceptable and ensure that each item of Product meets all aesthetic requirements **prior to installation**. Subject to the terms of this warranty, after installation of the Product, **we are not liable** for claims arising from aesthetic variations or defects if such variations or defects were, or would upon reasonable inspection have been, **apparent prior to installation**.

Making a Claim Under Warranty

If you are the property owner and did not purchase the product yourself, and you believe you have any issue with James Hardie product installed at your home, in the first instance you should contact the builder who purchased and installed the product. If you purchased the product yourself, you can make a claim under this warranty as detailed below.

8. In order to make a claim under this warranty, you must provide the following information in writing to us using the contact details below within 30 days after the alleged defect would have become reasonably apparent or, if the defect was reasonably apparent prior to installation, then the claim must be made prior to installation:
 - (a) proof of purchase;
 - (b) description of the defect and the issue;
 - (c) photographs of the defect; and
 - (d) your contact details.
9. Subject to New Zealand Consumer Law, you must bear any expenses you incur as a result of claiming under this warranty, except where you are entitled to recover such expenses under the New Zealand Consumer Law, in which case we will bear or otherwise reasonably compensate you for such expenses. All claims for such expenses are to be notified to us in writing within 21 days from the later of: when you make a claim under this warranty; or when we notify you that we, acting reasonably, accept responsibility for these expenses.

New Zealand Consumer Law

10. If you acquire the Product or accessories manufactured or supplied by us as a Consumer, that Product or accessories may come with guarantees that cannot be excluded under the Consumer Guarantees Act. If so, and we are a supplier, you are entitled to a replacement or refund for a failure of a substantial character or a failure that cannot be remedied, and compensation for any other reasonably foreseeable loss or damage. You are also entitled to have the goods repaired or replaced if the goods fail to be of acceptable quality or fail to meet some other guarantee and can be remedied and the failure is not of a substantial character. Where we or a related entity are the manufacturer, then you will have the rights set out in the Consumer Guarantees Act if the goods do not comply with this warranty or the consumer guarantees under the Consumer Guarantees Act.
11. Other than as lawfully excluded or limited by the other terms of this warranty, any rights a Consumer may have under this warranty are in addition to other rights and remedies of a Consumer under a law in relation to the goods to which this warranty relates. Nothing in this warranty shall exclude or modify any legal rights a purchaser and/or Consumer may have under the Consumer Guarantees Act, Fair Trading Act or otherwise which cannot be excluded or modified at law.

Disclaimer

The recommendations in James Hardie's literature are based on good building practice but are not an exhaustive statement of all relevant information. Further, as the successful performance of the relevant system depends on numerous factors outside the control of James Hardie (e.g. quality of workmanship and design) James Hardie shall not be liable for the recommendations made in that Technical Literature and the performance of the relevant system, including its suitability for any purpose or ability to satisfy the relevant provisions of the NZBC, laws, regulations and standards. It is the responsibility of the building designer to ensure that the details and recommendations provided in the relevant James Hardie Technical Literature are suitable for the intended project and that specific design is conducted where appropriate.

Our Contact Details

James Hardie New Zealand Limited

Address: 1 O'Rorke Road, Penrose, Auckland, 1061

Postal address: PO Box 12070, Penrose, Auckland 1642

Telephone: "Ask James Hardie™" on 0800 808 868

Website: www.jameshardie.co.nz

Email: info@jameshardie.co.nz

