



Installation Manual

Content

1	INTRODUCTION	3	7	MAINTENANCE	13
	Product Description	4			
	Accessories	4			
2	SAFE WORKING PRACTICES	5	8	PRODUCT INFORMATION	13
2.1	Storage and Delivery	6	8.1	General	13
2.2	Tips for Safe and Easy Handling of Secura Interior Flooring	6	8.2	Product Mass	13
		6	8.3	Durability	13
		6	8.4	Fire Properties	13
3	DESIGN	7		PRODUCT WARRANTY	15
3.1	General	7			
3.2	Loading Consideration	7			
3.3	Framing	7			
3.4	Sub Floor Ventilation	7			
3.5	Fastener Durability	7			
4	INSTALLATION	8			
4.1	Panel Layout	8			
4.2	Installation Steps	8			
4.3	Control Joints	8			
4.4	Preformed Trays and Bases	10			
5	WATERPROOFING MEMBRANE	11			
6	FINISHES	12			
6.1	General	12			
6.2	Preparation	12			
6.3	Vinyl	12			
6.4	Screeds	12			
6.5	Selection of Tiles	12			
6.6	Tile Adhesives	12			
6.7	Tiling	12			
6.8	Tiling Practice	12			

WE VALUE YOUR FEEDBACK

To continue with the development of our products and systems, we value your input. Please send any suggestions, including your name, contact details, and relevant sketches to:

Ask James Hardie™
literaturefeedback@jameshardie.co.nz

1 Introduction

Secura™ Interior Flooring is a substrate which has been specifically engineered for use in internal wet and dry areas such as bathrooms, toilets and laundries to overlay with tiles, heavy grade vinyl or carpeting. Secura Interior Flooring provides a durable, stable and moisture resistant substrate.

Secura Interior Flooring is manufactured using James Hardie's unique advanced lightweight fibre cement composite technology, making it easier to cut and gun nail.

Secura Interior Flooring is a 19mm thick structural tongue and groove flooring which is an alternative to timber, particle board or plywood flooring. It's lighter than traditional James Hardie 18mm HardiePanel™ Compressed Sheet thus making it easier to handle and install.

The 19mm thickness and tongue and groove joining means Secura Interior Flooring is compatible with other 19mm flooring products on the market and eliminates the need for timber blocking along the tongue and groove joint. The moisture-resistant sealer on all six sides combined with the high strength technology makes it suitable for use in wet and dry areas. Tiles and heavy grade vinyl linings can be directly fixed to this substrate without the need for an underlay sheet.

Scope

This installation manual covers the use of Secura Interior Flooring in wet and dry areas of buildings within the scope of NZS 3604 or specific engineering design (SED) projects where the loading concentrations do not exceed those specified in NZS 3604 or mentioned in section 3.2.

Make sure your information is up to date

When specifying or installing James Hardie products, ensure you have the current manual. If you're not sure you do, or you need more information, visit www.jameshardie.co.nz or Ask James Hardie™ on 0800 808 868.

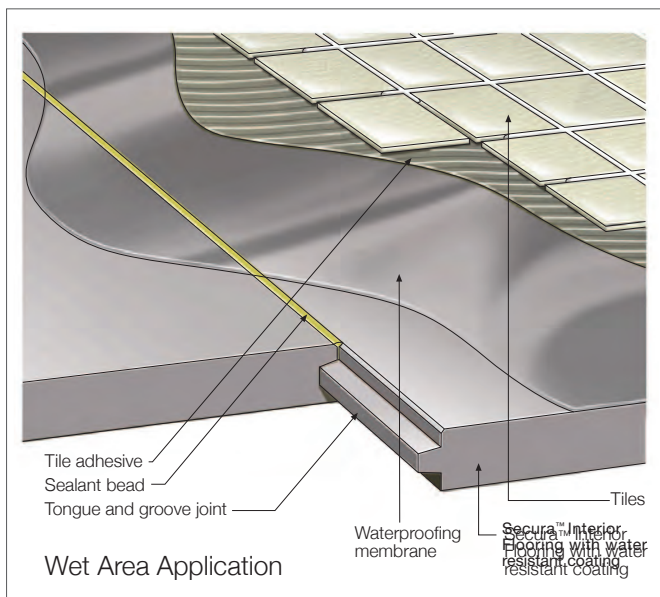

The specifier or other responsible party for the project must ensure the information and details in this manual are appropriate for the intended application and specific design and detailing is undertaken for areas which fall outside the scope of this documentation. This manual must be read in conjunction with the New Zealand Building Code (NZBC) and other relevant standards/regulations relating to wet/dry area construction.

Note: Secura Interior Flooring is not suitable for exterior flooring applications.

Table 1

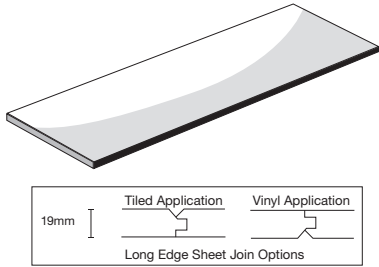







Product	Description	Size (mm)	Code
	<p>A structural flooring product sealed on all six sides for both tiled or heavy grade vinyl covered internal wet area flooring applications</p> <p>Long edges have a tongue and groove for easy jointing across the joists.</p> <p>Tiled applications: Install sheet with label 'This side down for Tiles' facing down</p> <p>Vinyl or Carpet applications: Install sheet with label 'This side UP for Vinyl' facing up</p>	2700 x 600	404260

All dimensions provided are approximate only and subject to manufacturing tolerances

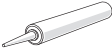
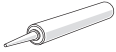
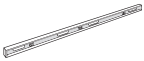
Table 2

Accessories	Description	Code
	<p>HardieBlade™ Saw Blade HardieBlade Saw Blade 184mm diameter Used to cut Secura Interior Flooring</p>	300660

James Hardie recommends the following products for use in conjunction with its flooring products. James Hardie does not supply these products and does not provide a warranty for their use. Please contact the component manufacturer for information on their warranties and further information on their products.

Accessories	Description	Accessories	Description
	<p>Backing rod PEF backing rod to be used with sealant in control joints.</p>		<p>Waterproofing membrane Used over the Secura Interior Flooring in wet areas. Use the recommended products and applications. Refer table 4.</p>
	<p>Sealant Sealant used in v joint in tiled applications, Ensure the sealant is compatible with the waterproofing membrane system selected.</p>		<p>Adhesive Adhesive used over joists prior to installation of Secura Interior Flooring. Bostik Seal 'n' Flex 1 Sika Sikaflex 11FC Bostik No more nails Gorilla Grip</p>
	<p>Level/straight edge For checking straightness of underlying flooring.</p>		<p>Screws for timber 10g x 40mm wood thread self embedding screws.</p>
 	<p>Paslode Impulse FrameMaster or Paslode Pneumatic Nailer</p>	 	<p>Screws for steel 8-10g x 40-45mm wing tek min. class 3 coating.</p> <p>50 x 2.87mm stainless steel ring RoundDrive nail</p> <p>50 x 2.87mm Dekfast HD galvanised RoundDrive nail</p>

2 Safe working practices

WARNING - DO NOT BREATHE DUST AND CUT ONLY IN WELL VENTILATED AREA

James Hardie products contain sand, a source of respirable crystalline silica. May cause cancer if dust from product is inhaled. Causes damage to lungs and respiratory system through prolonged or repeated inhalation of dust from product.

Intact fibre cement products are not expected to result in any adverse toxic effects. The hazard associated with fibre cement arises from the respirable crystalline silica present in dust generated by activities such as cutting, rebating, drilling, routing, sawing, crushing, or otherwise abrading fibre cement, and when cleaning up, disposing of or moving dust.

When doing any of these activities in a manner that generates dust, follow James Hardie instructions and best practices to reduce or limit the release of dust.

If using a dust mask or respirator, use an AS/NZS 1716 P1 filter and refer to Australian/New Zealand Standard 1715:2009 Selection, Use and Maintenance of Respiratory Protective Equipment for more extensive guidance and more options for selecting respirators for workplaces. For further information, refer to our installation instructions and Safety Data Sheets available at www.jameshardie.co.nz.

FAILURE TO ADHERE TO OUR WARNINGS, SAFETY DATA SHEETS, AND INSTALLATION INSTRUCTIONS MAY LEAD TO SERIOUS PERSONAL INJURY OR DEATH.

Crystalline Silica is

- Commonly known as sand or quartz
- Found in many building products e.g. concrete, bricks, grout, wallboard, ceramic tiles, and all fibre cement materials

Why is Crystalline Silica a health hazard?

- Silica can be breathed deep into the lungs when present in the air as a very fine (respirable) dust
- Exposure to silica dust without taking the appropriate safety measures to minimise the amount being breathed in, can lead to a potentially fatal lung disease – silicosis – and has also been linked with other diseases including cancer. Some studies suggest that smoking may increase these risks
- The most hazardous dust is the dust you cannot see!

When is Crystalline Silica a health hazard?

- It's dangerous to health if safety protocols to control dust are not followed when cutting, drilling or rebating a product containing crystalline silica and when cleaning up
- Products containing silica are harmless if intact (e.g. an un-cut sheet of wall board)

Avoid breathing in crystalline silica dust

Safe working practices

- ✗ NEVER use a power saw indoors or in a poorly ventilated area
- ✗ NEVER dry sweep
- ✓ ALWAYS use M Class or higher vacuum or damp down dust before sweeping up
- ✗ NEVER use grinders
- ✓ ALWAYS use a dust reducing circular saw equipped with a sawblade specifically designed to minimise dust creation when cutting fibre cement – preferably a sawblade that carries the HardieBlade™ logo or one with at least equivalent performance – connected to an M Class or higher vacuum
- ✓ Before cutting warn others in the area to avoid dust
- ✓ ALWAYS follow tool manufacturers' safety recommendations
- ✓ ALWAYS expose only the minimum required depth of blade for the thickness of fibre cement to be cut
- ✓ ALWAYS wear a properly-fitted, approved dust mask or respirator P1 or higher in accordance with applicable government regulations and manufacturer instructions
- ✓ Consider rotating personnel across cutting tasks to further limit respirable silica exposures.

When cutting Secura Interior Flooring

- ✓ Work outdoors only
- ✓ Make sure you work in a well ventilated area
- ✓ Position cutting station so wind will blow dust away from yourself and others in the working area
- ✓ Rotate employees across cutting task over duration of shift
- ✓ Cut products with a HardieBlade Saw Blade (or equivalent) and a dust reducing circular saw connected to a M Class or higher vacuum
- ✓ When sawing, sanding, rebating, drilling or machining fibre cement products, always:
 - Wear your P1 or higher (correctly fitted in accordance with manufacturers' instructions), ask others to do the same.
 - Keep persons on site at least 2 metres and as far as practicable away from the cutting station while the saw is in operation.
 - If you are not clean shaven, then use a powered air respirator with a loose fitting head top
 - Wear safety glasses
 - Wear hearing protection
 - When others are close by, ask them to do the same
- ✓ Make sure you clean up BUT never dry sweep. Always hose down with water/wet wipe or use an M Class or higher vacuum

Working instructions

HardieBlade™ Saw Blade

The HardieBlade Saw Blade used with a dust-reducing saw is ideal for fast, clean cutting of James Hardie fibre cement products. A dust-reducing saw uses a dust collector connected to a M Class or higher vacuum. When sawing, clamp a straight edge to the sheet as a guide and run the saw base plate along the straight edge when making the cut.

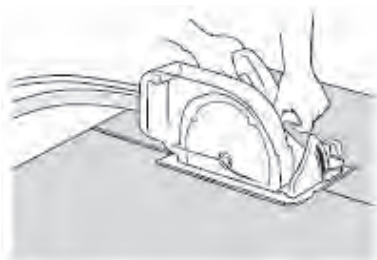

Hole forming

For smooth clean cut circular holes:

- Mark the centre of the hole on the sheet
- Pre-drill a 'pilot' hole
- Using the pilot hole as a guide, cut the hole to the appropriate diameter with a hole saw fitted to a heavy duty electric drill



For irregular holes:

- Small rectangular or circular holes can be cut by drilling a series of small holes around the perimeter of the hole then tapping out the waste piece from the sheet face
- Tap carefully to avoid damage to sheets, ensuring that the sheet edges are properly supported

2.1 STORAGE AND DELIVERY

Keeping products and people safe

Off loading

- James Hardie products should be off-loaded carefully by hand or by forklift
- James Hardie products should not be rolled or dumped off a truck during the delivery to the jobsite

Storage

James Hardie products should be stored:

- ✓ In their original packaging
- ✓ Under cover where possible or otherwise protected with a waterproof covering to keep products dry
- ✓ Off the ground – either on a pallet or adequately supported on timber or other spacers
- ✓ Flat so as to minimise bending

James Hardie products must not be stored:

- ✗ Directly on the ground
- ✗ In the open air exposed to the elements

James Hardie is not responsible for damage due to improper storage and handling.

2.2 TIPS FOR SAFE AND EASY HANDLING OF SECURA INTERIOR FLOORING

- ✓ Carry with two people
- ✓ Hold near each end and on edge
- ✓ Exercise care when handling sheet products to avoid damaging the edges/corners

3 Design

3.1 GENERAL

All construction must be carried out in accordance with the relevant building regulations and standards.

Prior to installation of Secura Interior Flooring, ensure the supporting framing is suitable and is in accordance with this manual.

A solvent free waterproofing membrane must be applied over the Secura Interior Flooring in internal wet areas prior to the installation of tiles.

3.2 LOADING CONSIDERATION

Secura Interior Flooring in this manual has been designed to satisfy the requirements for wet and dry areas for buildings within the scope of NZS 3604, 'Timber-framed Buildings', NASH 3405 'An Alternative Solution for Steel Framed Buildings' and load specified under domestic and residential activities of Table 3.1, (Category A) of AS/NZS 1170.1 'Structural Design Actions – Permanent, Imposed and Other Actions'.

Note: The Standard AS/NZS 1170 also specifies higher loads for areas in public buildings which are subject to crowd loading, storage of materials and heavy wheel loadings. For these applications James Hardie Panel Compressed Sheet shall be used. Refer to Flooring Installation Manual.

If in doubt, contact your builder, designer or engineer or Ask James Hardie 0800 808 868.

Notes:

- Secura Interior Flooring must NOT be used on concrete slabs. To build up height of concrete, purpose-made concrete levelling compounds are more suitable
- For tiling of walls use Villaboard™ Lining

3.3 FRAMING

3.3.1 Timber frame

Timber floor joists must either be in accordance with NZS 3604: 'Timber Framed Buildings' or be specifically designed as per NZS 3603 'Timber Structure Standard' considering the maximum loading specified in AS/NZS 1170 'Structural Design Actions' as explained above.

Floor joists must be 45mm minimum wide. The joist spacing must not exceed those given in Table 3.

Table 3

Secura Interior Flooring Fixing	
JOIST SPACING CENTRES (MAXIMUM)	FASTENER MAXIMUM SPACING CENTRES
450mm	200mm

In addition to any lateral support required, the floor joists must also be supported by continuous blocking or strutting as per section 7 of NZS 3604.

Moisture content in timber floor joists must not exceed 20% at the time of installation of Secura Interior Flooring.

For further timber treatment and allowable moisture content information refer to NZS 3602 'Timber and Wood-Based Products for use in Buildings' and NZS 3640 'Chemical Preservation of Round Sawn Timber' for minimum timber treatment selection and treatment requirements. Also refer to framing manufacturer's literature for further guidance on timber selection. Framing must be protected from moisture on site in accordance with the recommendations of the framing manufacturers.

Note: Tiles, tile grouts and adhesives can be detrimentally affected by even small deflections. Therefore it is recommended that for tiled applications reduce joist spans by 20% as specified in the NZS 3604.

3.3.2 Steel Frame

The use of steel framing must be in accordance with NASH 3405 Steel Frame Guide and the framing manufacturers' specifications. Framing members must be 0.75mm to 1.9mm BMT.

Steel frame must have appropriate level of coating to meet the durability requirement of Clause B2 of the NZBC.

3.4 SUB FLOOR VENTILATION

Check that adequate ventilation exists under all framed floors (especially new floors) and that the sub floor area is free from dampness. Refer to the NZS 3604 for ventilation requirements.

3.5 FASTENER DURABILITY

Fasteners must meet the minimum durability requirements of the NZBC.

Contact fastener manufacturers/suppliers for more information.

4 Installation

For floor joist spacing and sizes refer to Section 3.

4.1 PANEL LAYOUT

Secura Interior Flooring must always be installed across the floor joists with short sheet edges fully supported on joists. Secura Interior Flooring must be laid in staggered pattern. See Figure 1. No blocking is required under the tongue and groove joints.

When using the site cut sheet pieces, the minimum length of the cut sheet to be used must be 900mm or more.

All site cut sheets must be sealed with an acrylic sealer, Dulux Acraprime 501/1, Dulux 1 Step or similar that is compatible with the waterproofing membrane.

Tile and Vinyl Applications.

The sheets are laid in a staggered pattern. Ensure the sheets are facing the correct way down depending on the final finish ie. tiles or vinyl.

Note:

1. Install sheet with label 'This side down for tiles' facing down.
2. Install sheet with label 'This side up for vinyl' facing up.

Being 19mm thick, Secura Interior Flooring can easily be combined with traditional particle board or plywood flooring substrates.

Figure 1: Sheet layout - tile and vinyl

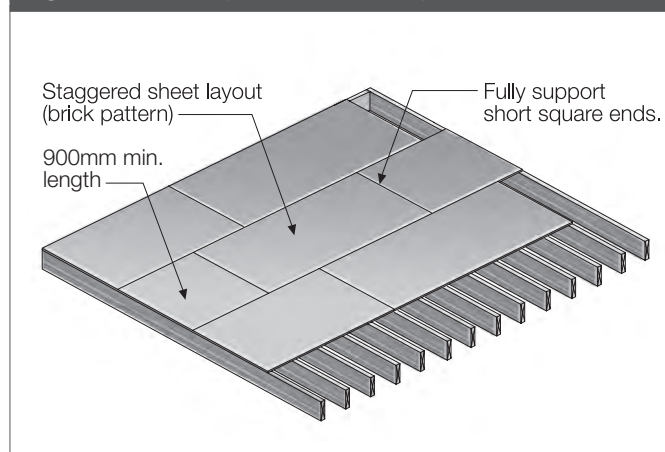

Fixings to be 50 x 2.87mm RoundDrive nails at 200mm maximum centres. Refer Table 3.

4.2 Installation Steps

You must ensure the product is of acceptable quality prior to installation.

The sheet is multi-purpose and depending on the finish, ensure sheet is laid with correct face upwards for the final desired finish.

The Secura Interior Flooring must not be exposed to exterior elements for more than 90 days.

4.3 CONTROL JOINTS

4.3.1 Tiled Floors

Control joints in Secura Interior Flooring sheets and the tiles are required in wet and dry areas where floor dimensions exceed 4.05m in the long sheet direction and where existing structural joints are located. Position joints symmetrically about the centre of the floor as shown in Figure 9. Additional control joints in the tiles may be required, refer to the current Good Tiling Practice Guide by BRANZ for more information available at www.branz.co.nz.

Figure 2: Fastener layout

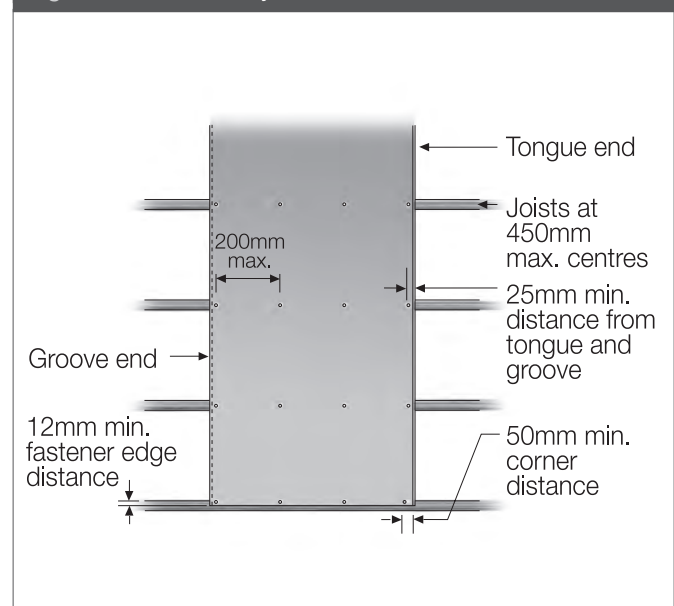

Figure 3: Construction adhesive

STEP 1

Apply a 6mm continuous bead of construction adhesive to joists.

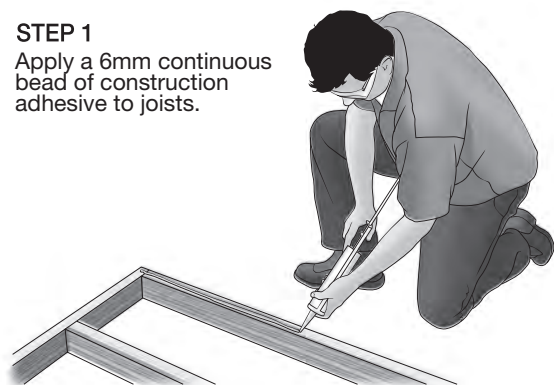
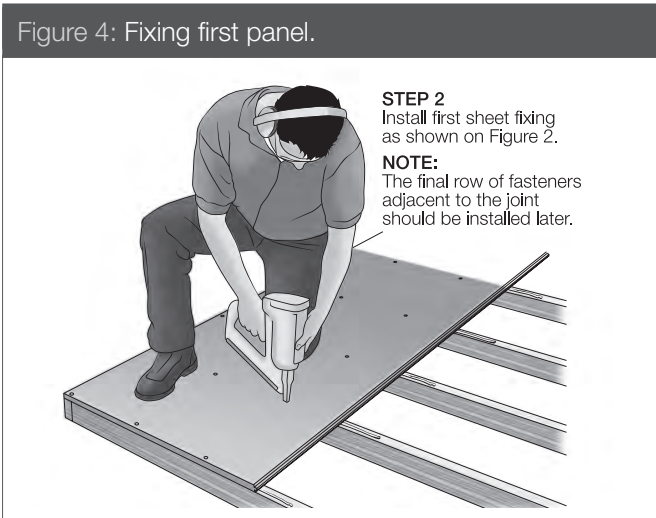

Figure 4: Fixing first panel.



Fixings to be 50 x 2.87mm RounDrive nails at 200mm maximum centres

Figure 7: Butt joint internal wet areas - tile floor

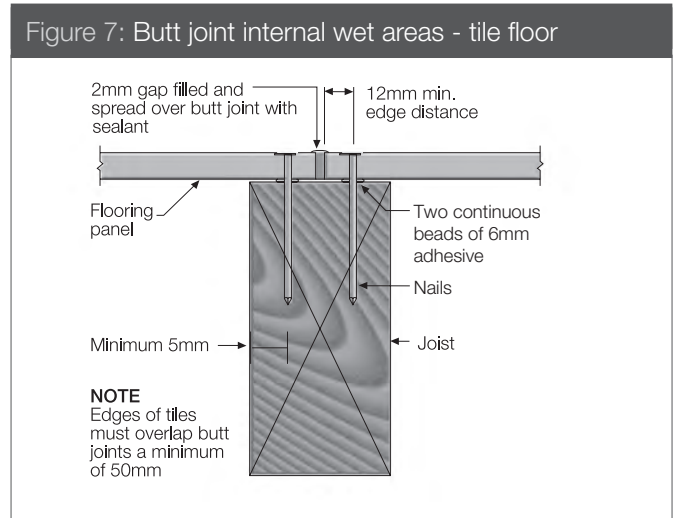

Figure 5: Nailing second panel

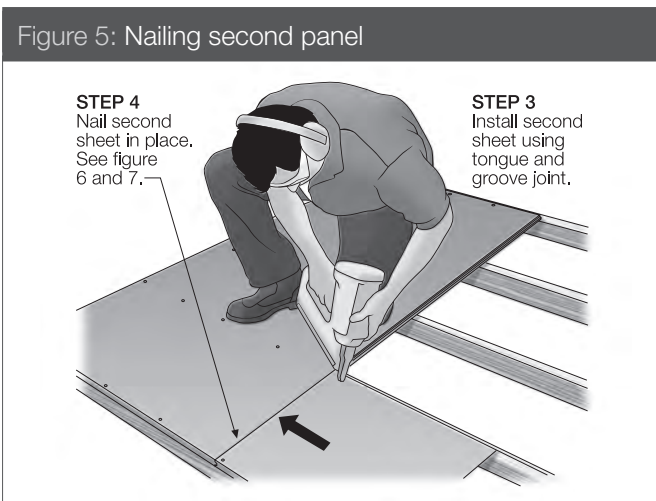

Figure 8: Butt joint internal dry/wet areas - vinyl floor

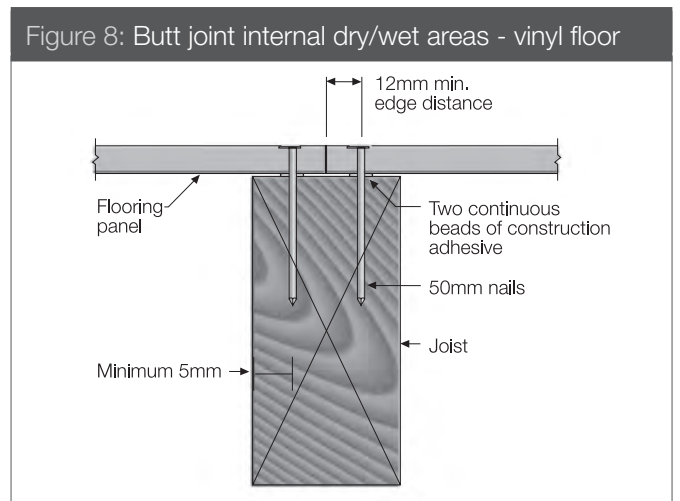

Figure 6: Sealing over fasteners - wet areas only

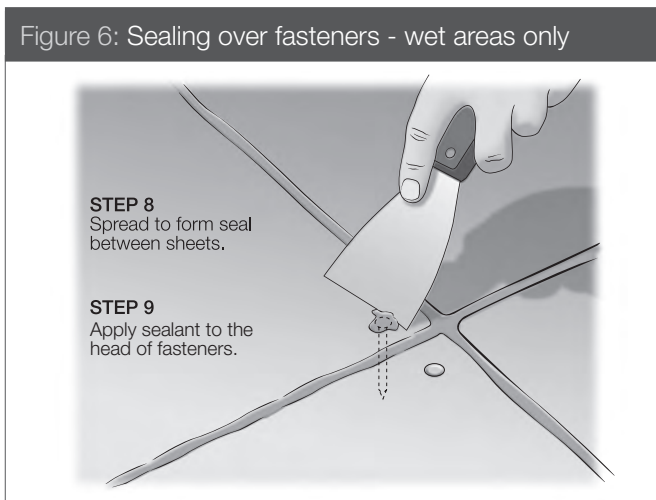
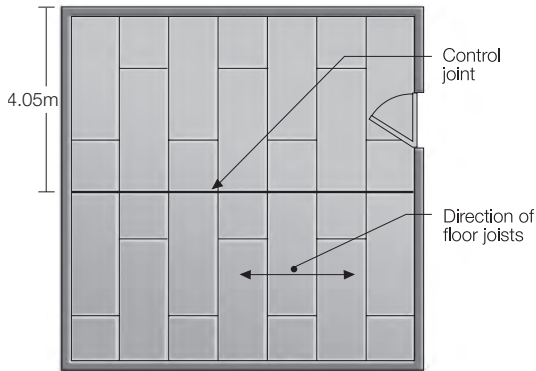
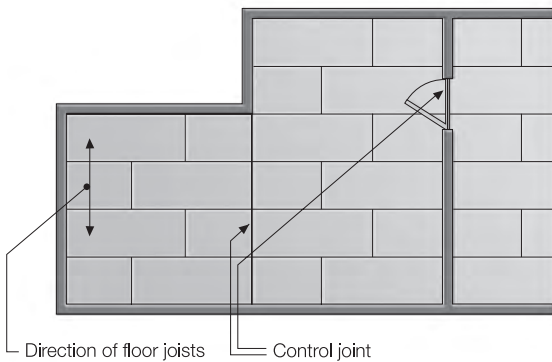

Figure 9: Control joint layout



Also provide control joints where there are changes of direction, such as an L-shaped room, and at doorways where the tiled surface is carried through to the next room as shown in Figure 10.

Figure 10: L shaped room



Place a 6-8mm diameter polyethylene backing rod in the bottom of the joint between the sheets and fill the joint with a suitable flexible sealant. All square edges must be fully supported as per Figure 11.

It is important that the control joints be carried through to the top of the floor surface i.e. they should not be covered OVER by tiles.

Note: No control joints are required in the flooring sheets when finishing with vinyl unless there is an existing structural joint or otherwise specified by relevant code and regulation.

Figure 11: Control joint

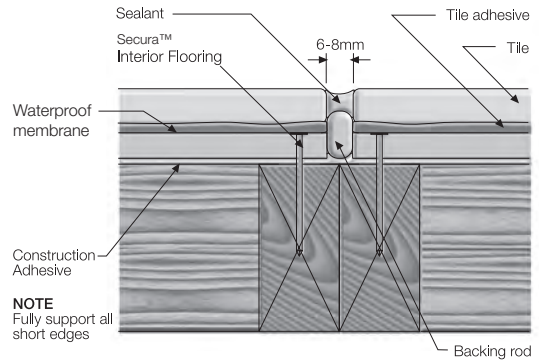
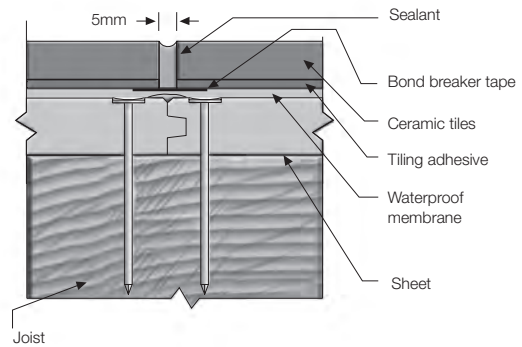

Figure 12 Tile control joint over tongue and groove joint



4.4 PREFORMED TRAYS AND BASES

Prefomed trays and bases must be installed to manufacturer's instructions.

Figure 13: Performed tray detail for Villaboard Lining to be tiled

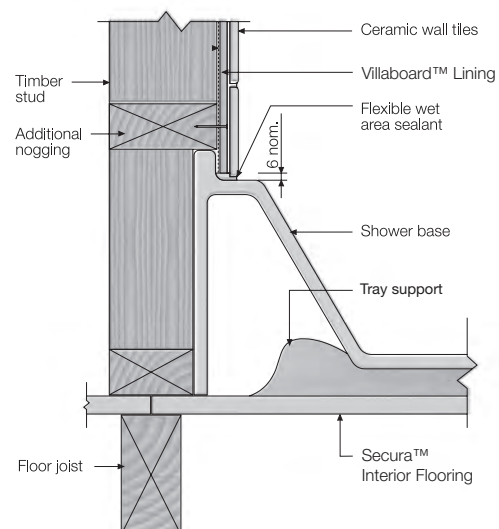

5 Waterproofing Membrane

All Secura Interior Flooring under showers (wet areas) must be waterproofed prior to tiling. Refer to clause E3 Internal Moisture of the NZBC and AS 3740 for further guidance regarding the definition of wet areas.

All sheet fixing must be completed as per this installation manual before the primer and the solvent free waterproofing membrane is applied.

Ensure the sheet is dry and free from surface dust and dirt before applying the primer.

The primer and waterproof membrane can be applied directly over the flush nail heads. Ensure compatibility of sealants with waterproofing membranes.

Only water based waterproofing membranes/chemicals must be used with Secura Interior Flooring. Follow the manufacturer's instructions for coverage areas, and specific instructions. For suitable Waterproofing Manufacturers refer to Table 4.

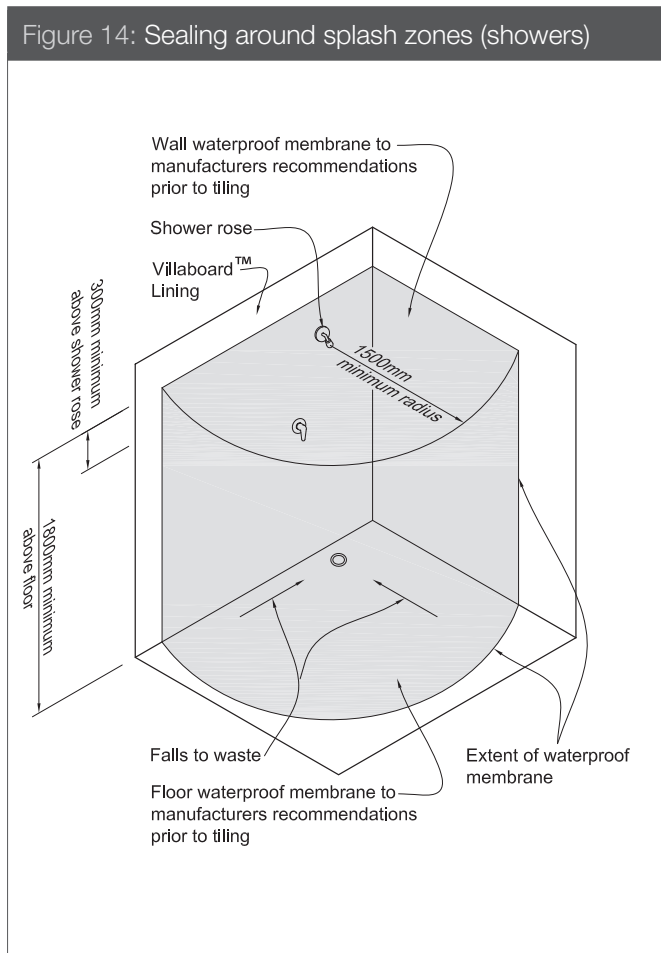

Prime sheet and apply coat of selected waterproof membrane with associated mesh as per waterproof manufacturers' recommendations.

Figure 15: Waterproofing floor to wall

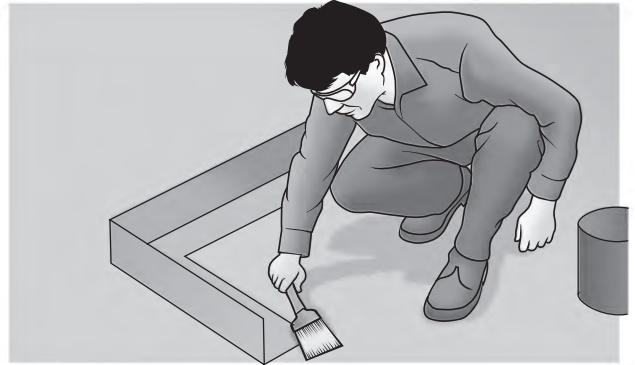

Figure 16: In-situ applied internal membrane

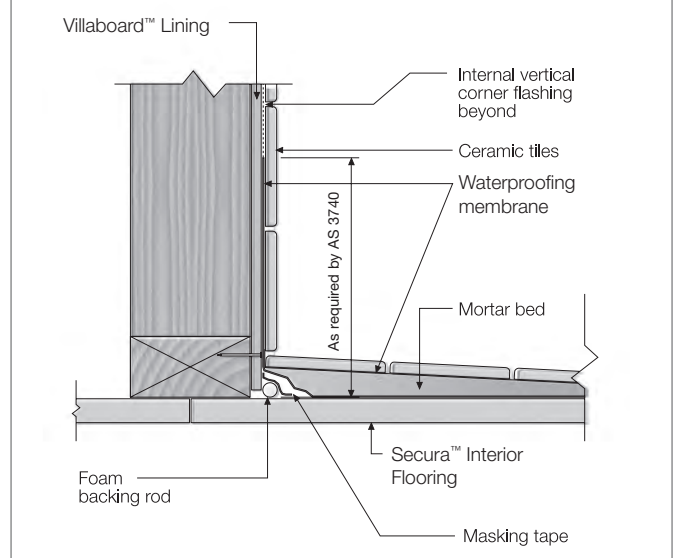

Table 4

Recommended waterproofing membranes/tile adhesives
ASA Waterproofing Membrane Dampfix 2 from Bostik
Mapegum WPS and Mapelastic from Mapei NZ Ltd.
Superflex® Ardex Liquid Membranes' from Ardex NZ Ltd
Flexi-Seal® from Flexco (NZ) Ltd
Gripset 38® and Gripset2P® from Waterproofing Systems Ltd

All waterproofing membranes specified above are water based membranes. Use only water based membranes over Secura Interior Flooring.

For coverage information of the selected waterproof membrane refer to manufacturer's recommendations.

Waterproofing membranes must be applied in accordance with their manufacturer's requirements.

Note: Refer to AS 3740 for further guidance on waterproofing requirements.

6 Finishes

6.1 GENERAL

Secura Interior Flooring must be finished with a suitable floor covering to suit the intended application. For the suitability and installation requirements of floor coverings, check with the manufacturer.

6.2 PREPARATION

Where minor height variations (3mm or less) occur at butt joints, these may be levelled out by filling with self levelling compounds eg. Ardex Feather Finish or equivalent. Ensure final finish is compatible with all components eg. vinyl adhesive with leveling compound.

Sanding of the Secura Interior Flooring is not recommended.

6.3 VINYL

As the sheets are supplied fully sealed, only water based vinyl adhesives must be used for this application.

Allow the adhesive to air dry before the vinyl is applied. Refer to a reputable vinyl manufacturer for suitable products and installation instructions.

6.4 SCREEDS

Where the application requires the flooring to have falls created, a mortar bed screed may be used. The surface of the flooring must be thoroughly clean and dry prior to applying the screed as per manufacturer's instructions. To prevent cracking of floor tiles, the mortar bed must be reinforced over all joints in flooring sheets.

6.5 SELECTION OF TILES

The following brief notes do not cover all aspects of tiling. Further advice should be sought from specialists in these areas.

The importance of choosing the proper tile for a given environment cannot be stressed enough. Manufacturer's catalogues indicate the recommended uses and limitations of their products and should be consulted when unsure.

6.6 TILE ADHESIVES

Because of possible differential movement between tiles and the Secura Interior Flooring only approved flexible adhesive and grouts must be used.

Refer to the adhesive manufacturers' specifications for sheet preparation before applying the flexible tile adhesive.

The recommended brands of waterproof membranes and tile adhesives are shown in Table 4. It is essential that all tile systems such as primers, waterproofing membranes, flexible adhesives and grouts are all supplied by the same manufacturer to ensure compatibility of products and warranty protection.

6.7 TILING

Tiles should be applied with proprietary adhesive that conform to AS 2358 and installed in accordance to the AS 3958.1 and to tile and adhesive manufacturer recommendations. Use a flexible tile adhesive recommended for internal wet area applications and compatible with all other materials.

It is recommended that tiles are laid from the control joint out and the edges of tiles must overlap butt joints a minimum of 50mm.

Ensure the tile adhesive used is suitable and compatible with adjoining surfaces for the intended application.

Refer to the waterproofing and tile manufacture and relevant tiling standards for maximum tile control joint spacing, product suitability and compatibility including grout, tile adhesive, tile and waterproofing warranty and maintenance requirement.

The waterproofing requirements of the AS 3740 and clause E3 of the NZBC must be met. Once Secura Interior Flooring has been fixed in place, install flooring material in accordance with manufacturer's specifications within three months of Secura Interior Flooring installation.

6.8 TILING PRACTICE

Refer to the selected tile manufacturer for complete details regarding the laying and fixing of the ceramic tiles, marble, slate and granite stone. Reference can also be made to the BRANZ publication "Good Tiling Practice" available at www.branz.co.nz.

7 Maintenance

Regular cleaning, checks and maintenance of the finished surface, joints, junctions, penetrations, sealant, grout etc must be carried out at regular intervals and as per manufacturers' recommendations.

Maintain waterproofing membranes to meet the objectives of Clause B2 of the NZBC and as per the requirements of the relevant component manufacturer.

8 Product information

8.1 GENERAL

Secura Interior Flooring is an advanced lightweight cement composite building product. The basic composition is Portland cement, ground sand, cellulose fibre and water.

Secura Interior Flooring is manufactured to AS/NZS 2908.2 'Cellulose- Cement Products Part 2: Flat Sheets' (ISO 8336 'Fibre Cement Flat Sheets').

Secura Interior Flooring is a classified Type B, Category 2 in accordance with AS/NZS 2908.2 'Cellulose-Cement Products'.

8.2 PRODUCT MASS

Based on equilibrium moisture content the approximate mass of:

- Secura Interior Flooring is 24.5kg/m².

8.3 DURABILITY

Resistance to moisture/rotting

Secura Interior Flooring has demonstrated resistance to permanent moisture induced deterioration (rotting) by having passed the following tests in accordance with the AS/NZS 2908.2:

- Heat rain (Clause 6.5)
- Water permeability (Clause 8.2.2)
- Warm water (Clause 8.2.4)
- Soak dry (Clause 8.2.5)

8.4 FIRE PROPERTIES

Secura Interior Flooring is classified as a 'non-combustible material'.

Product Warranty



James Hardie New Zealand Limited ("James Hardie") warrants for a period of 15 years from the date of purchase that the Secura™ Interior Flooring (the "Product"), will be free from defects due to defective factory workmanship or materials and, subject to compliance with the conditions below, will be resistant to cracking, rotting, fire and damage from termite attacks to the extent set out in James Hardie's relevant published literature current at the time of installation. James Hardie warrants for a period of 12 months from the date of purchase that the accessories supplied by James Hardie will be free from defects due to defective factory workmanship or materials.

Nothing in this document shall exclude or modify any legal rights a customer may have under the Consumer Guarantees Act or otherwise which cannot be excluded or modified at law.

CONDITIONS OF WARRANTY:

The warranty is strictly subject to the following conditions:

- a) James Hardie will not be liable for breach of warranty unless the claimant provides proof of purchase and makes a written claim either within 30 days after the defect would have become reasonably apparent or, if the defect was reasonably apparent prior to installation, then the claim must be made prior to installation;
- b) this warranty is not transferable;
- c) the Product must be installed and maintained strictly in accordance with the relevant James Hardie literature current at the time of installation and must be installed in conjunction with the components or products specified in the literature. Further, all other products, including coating and jointing systems, applied to or used in conjunction with the Product must be applied or installed and maintained strictly in accordance with the relevant manufacturer's instructions and good trade practice;
- d) the project must be designed and constructed in strict compliance with all relevant provisions of the current NZBC, regulations and standards;
- e) the claimant's sole remedy for breach of warranty is (at James Hardie's option) that James Hardie will either supply replacement product, rectify the affected product or pay for the cost of the replacement or rectification of the affected product;
- f) James Hardie will not be liable for any losses or damages (whether direct or indirect) including property damage or personal injury, consequential loss, economic loss or loss of profits, arising in contract or negligence or howsoever arising. Without limiting the foregoing James Hardie will not be liable for any claims, damages or defects arising from or in any way attributable to poor workmanship, poor design or detailing, settlement or structural movement and/or movement of materials to which the Product is attached, incorrect design of the structure, acts of God including but not limited to earthquakes, cyclones, floods or other severe weather conditions or unusual climatic conditions, efflorescence or performance of paint/coatings applied to the Product, normal wear and tear, growth of mould, mildew, fungi, bacteria, or any organism on any Product surface or Product (whether on the exposed or unexposed surfaces);
- g) all warranties, conditions, liabilities and obligations other than those specified in this warranty are excluded to the fullest extent allowed by law;
- h) if meeting a claim under this warranty involves re-coating of Products, there may be slight colour differences between the original and replacement Products due to the effects of weathering and variations in materials over time.

Disclaimer: The recommendations in James Hardie's literature are based on good building practice, but are not an exhaustive statement of all relevant information and are subject to conditions (c), (d), (f) and (g) above. James Hardie has tested the performance of the Secura Interior Flooring when installed in accordance with the Secura Interior Flooring Installation Manual, in accordance with the standards and verification methods required by the NZBC and those test results demonstrate the product complies with the performance criteria established by the NZBC. However, as the successful performance of the relevant system depends on numerous factors outside the control of James Hardie (e.g. quality of workmanship and design) James Hardie shall not be liable for the recommendations made in its literature and the performance of the relevant system, including its suitability for any purpose or ability to satisfy the relevant provisions of the NZBC, regulations and standards, as it is the responsibility of the building designer to ensure that the details and recommendations provided in the relevant James Hardie installation manual are suitable for the intended project and that specific design is conducted where appropriate.

Copyright 2020. © James Hardie New Zealand Limited. TM and ® denotes a Trademark or Registered Mark owned by James Hardie Technology Limited.

